

NM, NMD 60 Hz



Close Coupled Centrifugal Pumps with threaded ports
Bombas centrífugas monobloc con orificios roscados



Coverage chart - Campo de aplicaciones

n ≈ 3450 rpm

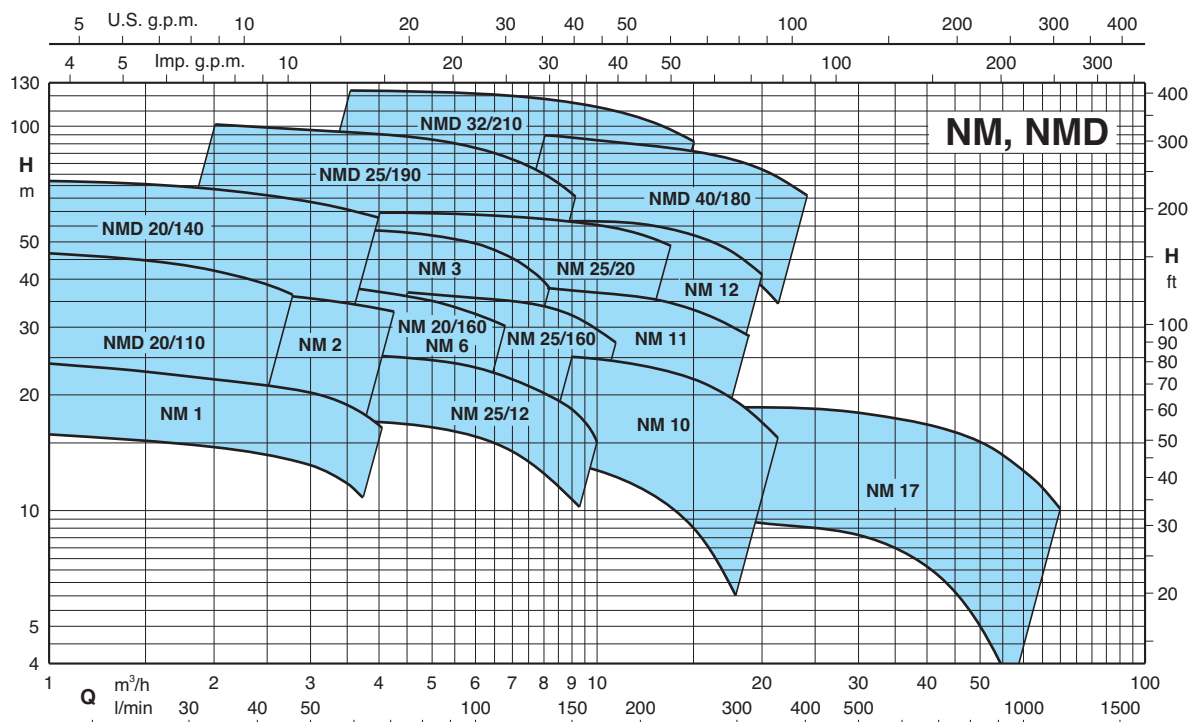

Construction

Close-coupled, centrifugal pumps; electric motor with extended shaft directly connected to the pump.

NM: single-impeller

NMD: with two back-to-back impellers (with axial thrust balancing).

Connections: threaded ports **ISO 228/1**.

threaded ports **NPT** (ANSI/ASME B1.20.1) on request

NM, NMD: version with pump casing and lantern bracket in cast iron.

B-NM, B-NMD: version with pump casing and lantern bracket in bronze. (the pumps are supplied fully painted).

Applications

- For clean liquids without abrasives, which are, non-aggressive for the pump materials (solids content up to 0.2%).
- For water supply.
- For heating, air-conditioning, cooling and circulation plants.
- For civil and industrial applications.
- For fire fighting applications.
- For irrigation.

Operating conditions

Liquid temperature from -10 °C to +90 °C.

Ambient temperature up to 40 °C.

Total suction lift up to 7 m.

Maximum permissible working pressure up to 10 bar

(16 bar for pumps NMD 25/190; NMD 32/210; NMD 40/180).

Continuous duty.

Motor

2-pole induction motor, 60 Hz (n ≈ 3450 rpm).

NM, NMD: three-phase 220/380 V, 220/440 V, up to 3 kW;

380/660 V, from 4 to 9,2 kW;

NMM, NMDM: single-phase 110 V, 127 V, 220 V, 110/220 V.

With thermal protector up to 1.1 kW only 220V.

Insulation class F.

Protection IP 54.

Motor suitable for operation with frequency converter from 1,1 kW.

Classification scheme IE3 for three-phase motors from 0,75 kW.

Constructed in accordance with EN 60034-1; EN 60034-30.

EN 60335-1, EN 60335-2-41.

Special features on request

- Other voltages.
- Protection IP 55.
- Special mechanical seal
- Higher or lower liquid or ambient temperatures.
- Motor suitable for operation with frequency converter up to 0,75 kW.

Materials

Components	NM, NMD	B-NM, B-NMD
Pump casing	Cast iron	Bronze
Lantern bracket	GJL 200 EN 1561	G-Cu Sn 10 EN 1982
Impeller	Brass P- Cu Zn 40 Pb 2 UNI 5705	
NM 17	Cast iron	Bronze
	GJL 200 EN 1561	G-Cu Sn 10 EN 1982
Shaft	Cr steel AISI 430	Cr Ni Mo steel AISI 316
	Cr Ni steel AISI 303 1,1 -1,5 - 2,2 kW	
Mechanical seal	Carbon - Ceramic - NBR	

Ejecución

Electrobombas centrífugas monobloc con acoplamiento directo motor-bomba y eje único.

NM: con un rodete.

NMD: con dos rodetes contrapuestos (con empuje axial equilibrado).

Orificios: Roscados **UNI-ISO 228/1**.

Roscados **NPT** (ANSI/ASME B1.20.1) bajo demanda.

NM, NMD: Ejecución con cuerpo bomba y acoplamiento en hierro.

B-NM, B-NMD: Ejecución con cuerpo bomba y acoplamiento en bronce.

(Las bombas en bronce se suministran totalmente pintadas).

Aplicaciones

- Para líquidos limpios sin partes abrasivas, y no agresivas para los materiales de la bomba (con partes sólidas hasta 0,2% máx).
- Para el aprovisionamiento de agua.
- Para instalaciones de calefacción, acondicionamiento, refrigeración y circulación.
- Para aplicaciones civiles e industriales.
- Para instalaciones contra incendios. - Para irrigación.

Límites de empleo

Temperatura del líquido de -10 °C a +90 °C.

Temperatura ambiente hasta 40 °C.

Altura de aspiración manométrica hasta 7 metros.

Presión final máxima admitida en el cuerpo de la bomba 10 bar.

(16 bar para bombas NMD 25/190; NMD 32/210; NMD 40/180).

Servicio continuo.

Motor

Motor a inducción a 2 polos, 60 Hz (n = 3450 1/min).

NM, NMD: trifásico 220/380 V, 220/440 V, hasta 3 kW;

380/660 V, de 4 a 9,2 kW;

NMM, NMDM: monofásico 110 V, 127 V, 220 V, 110/220 V.

con protector térmico hasta 1,1 kW sólo para 220V.

Aislamiento clase F.

Protección IP 54.

Motor preparado al funcionamiento con convertidor de frecuencia de 1,1 kW.

Clase alta eficiencia IE3 para motor trifásico de 0,75 kW.

Ejecución según EN 60034-1; EN 60034-30.

EN 60335-1, EN 60335-2-41.

Otras ejecuciones bajo demanda

- Otras tensiones.
- Protección IP 55.
- Sello mecánico especial.
- Para líquidos o ambientes con temperaturas más elevadas o más bajas.
- Motor preparado al funcionamiento con convertidor de frecuencia hasta 0,75 kW.

Materiales

Componentes	NM, NMD	B-NM, B-NMD
Cuerpo bomba	Hierro	Bronce
Acoplamiento	GJL 200 EN 1561	G-Cu Sn 10 EN 1982
Rodete	Latón P- Cu Zn 40 Pb 2 UNI 5705	
NM 17	Hierro	Bronce
	GJL 200 EN 1561	G-Cu Sn 10 EN 1982
Eje	Acero al Cr AISI 430	Acero al Cr Ni Mo AISI 316
	Acero al Cr Ni AISI 303 de 1,1-1,5-2,2 kW	
Sello mecánico	Carbón - Cerámica - NBR	

Performance - Prestaciones

n ≈ 3450 rpm

	NM	P ₂		Q m ³ /h	1	1,2	1,5	1,89	2,4	3	3,6	4,2	4,8	5,4	6	6,6	7,5	8,4
		kW	HP		16	20	25	31,5	40	50	60	70	80	90	100	110	125	140
				l/min	H m													
	NM 1/AE-60●	0,37	0,5	22	21,8	21,5	21	20,6	19,4	18,1	16,3	14,2						
	NM 1/S-60●	0,45	0,6	26	25,9	25,6	25,2	24,6	23,8	22,7	21,3	19,5						
	NM 2/B-60/A●	0,55	0,75	27	26,5	26	25,5	25	24	23	22	20						
	NM 2/S-60/A●	0,55	0,75	32	31,5	31	30,5	30	28	25,5	23	19,5						
	NM 2/A-60/B●	0,75	1	36	35,5	35	34,5	34	32,5	31,5	30	28,5	27					
	NM 6/B-60●	0,75	1	31,7	31,6	31,4	31,1	30,7	30	29,2	28,1	26,7	25	23	20,6	16,2		
	NM 6/A-60●	1,1	1,5	36,6	36,4	36,3	36	35,6	35	34,3	33,3	32,2	30,7	28,8	26,6	22,5	17,2	
	NMM 3/CE-60	1,1	1,5		39,5	39	39	38	37	36,5	35	33,5						
	NM 3/C-60/A	1,1	1,5		40	39,5	39,5	39	38	37	36	34	32*	29*				
	NMM 3/BE-60	1,5	2		45,5	45	45	44,5	44	43	42	41	39*	36*	32*			
	NM 3/B-60/A	1,5	2		47	46,5	46	45,5	45	44,5	43,5	42	40*	37*	33,5*	28*		
	NMM 3/A-60/A	1,8	2,5		53	53	53	53	52,5	52	51	49,5	48	45,5	42	35,5	27	
	NM 3/A-60/B	2,2	3		55,5	55	54,5	54	53,5	53	52,5	52	51*	49*	46,5*	42*	35*	

B-NM B-NMD	NM NMD	P ₂		Q m ³ /h	1	1,2	1,5	1,89	2,4	3	3,6	4,2	4,8	5,4	6	6,6	7,5	8,4
		kW	HP		16	20	25	31,5	40	50	60	70	80	90	100	110	125	140
				l/min	H m													
B-NMD 20/110B-60/A●	NMD 20/110B-60/A●	0,45	0,6	36,5	35,5	34	32	28,5	24	19*								
B-NMD 20/110Z-60/A●	NMD 20/110Z-60/A●	0,55	0,75	41	40	38	36	32,5	28	23	17*							
B-NMD 20/110A-60/B●	NMD 20/110A-60/B●	0,75	1	47	46,5	45	42,5	39	34	29	23,5*							
B-NMDM 20/140BE-60	NMDM 20/140BE-60	1,1	1,5	59	58,5	58	57	55	52	47,5								
B-NMD 20/140B-60/A	NMD 20/140B-60/A	1,1	1,5	60	59,5	59	58	56	53	49	45							
B-NMDM 20/140AE-60	NMDM 20/140AE-60	1,5	2	66,5	65,5	65	64	62,5	60	57,5	55	51	47,5					
B-NMD 20/140A-60/A	NMD 20/140A-60/A	1,5	2	77	76,5	76	75	73,5	71	69	66	63	59	54				
B-NM 20/160BE-60●	NM 20/160BE-60●	0,75	1				33	33	32	31	30	28,5	26,5	25	23*			
B-NM 20/160A-60/A●	NM 20/160A-60/A●	1,1	1,5				39	38,5	38	37	36	35	34	33	31*			

B-NM B-NMD	NM NMD	P ₂		Q m ³ /h	2,4	3	3,6	4,8	6	6,6	7,5	8,4	9,6	10,8	12	13,2	15	16,8	18
		kW	HP		40	50	60	80	100	110	125	140	160	180	200	220	250	280	300
				l/min	H m														
B-NM 25/12B-60/A●	NM 25/12B-60/A●	0,55	0,75	20,8	20,8	20,7	20,3	19,6	19,2	18,4	17,6	16,1	14,3	12	9,3				
B-NM 25/12A-60/B●	NM 25/12A-60/B●	0,75	1	24,5	24,6	24,6	24,3	23,6	23,1	22,4	21,6	20,4	19	17	14,5				
B-NM 25/160B-60/A●	NM 25/160B-60/A●	1,1	1,5		32	31,5	31	30	29	28	26,5	23,5*							
B-NM 25/160A-60/A●	NM 25/160A-60/A●	1,5	2		38	37,5	37	36	35,5	34,5	33	31	27,5	22,5*					
B-NM 25/200B-60/C	NM 25/20B-60/C	2,2	3	44,3	44	43,7	43,2	42,6	42,1	41,5	40,8	39,6	38,1	36,3	34	30,1			
B-NM 25/200A-60/B	NM 25/20A-60/B	3	4	52,0	51,7	51,6	51,2	50,7	50,3	49,8	49,2	48,2	47,1	45,7	43,9	40,9	37,2		
B-NM 25/200S-60/C	NM 25/20S-60/C	4	5,5	60,2	60	59,8	59,4	58,8	58,5	58	57,4	56,6	55,6	54,5	53	50,5	47,4	44,5	
B-NMD 25/190C-60/B	NMD 25/190C-60/B	2,2	3	69	67	65	60	53	50	42									
B-NMD 25/190B-60/A	NMD 25/190B-60/A	3	4	81	80	78	73	67,5	64	58	51,5	41*							
B-NMD 25/190A-60/B	NMD 25/190A-60/B	4	5,5	98	97	95	92	87	84	79	72,5	63*							

	NM	P ₂		Q m ³ /h	6,6	7,5	8,4	9,6	10,8	12	13,2	15	16,8	18,9	21	24	27	30
		kW	HP		110	125	140	160	180	200	220	250	280	315	350	400	450	500
				l/min	H m													
	NM 10/FE-60●	0,55	0,75	12,4	12,1	11,7	11,1	10,4	9,6	8,6	7							
	NM 10/DE-60●	0,75	1	18,8	18,5	18,3	17,8	17,2	16,5	15,8	14,4							
	NM 10/A-60/A●	1,1	1,5	24,3	24,1	23,8	23,4	22,8	22,2	21,4	20,1							
	NM 10/S-60/A●	1,5	2	25,2	25	24,8	24,3	23,8	23,2	22,5	21,2	19,7	17,8	15,6	12			
	NMM 11/BE-60	1,5	2	29,5	29	28,5	28	27	26	25	22,5	20						
	NM 11/B-60/A	1,5	2	31	30,5	30	29,5	29	28	27	25	23*						
	NMM 11/A-60/B	2,2	3	35,7	35,4	35,2	34,7	34,2	33,6	32,8	31,6	30						
	NM 11/A-60/B	2,2	3	39	38,8	38,5	38	37,4	36,6	35,8	34,4	32,8						
	NM 12/D-60/B	2,2	3	39	38	37,5	36,5	35	34	32*								
	NM 12/C-60/A	3	4	45	44,5	44	43	42	41	40	37	34*						
	NM 12/A-60/B	4	5,5	57	56,5	56	55,5	55	54	53	51	49*						

Performance - Prestaciones

n ≈ 3450 rpm

B-NMD	NMD	P ₂		Q m³/h l/min	5,4	6	6,6	7,5	8,4	9,6	10,8	12	13,2	15	16,8	18,9	21	24
		kW	HP		90	100	110	125	140	160	180	200	220	250	280	315	350	400
B-NMD 32/210D-60/B	NMD 32/210D-60/B	4	5,5	H m	68	67	65	63	60	55	50	45	40*					
B-NMD 32/210C-60/A	NMD 32/210C-60/A	5,5	7,5		89	88	87	85	83	79	74	68	63	52*				
B-NMD 32/210B-60/A	NMD 32/210B-60/A	7,5	10		110	109	108	106	104	100	96	91	86	78*				
B-NMD 32/210A-60/A	NMD 32/210A-60/A	9,2	12,5		121	120	119	118	117	114	110	105	99	89*				
B-NMD 40/180D-60/B	NMD 40/180D-60/B	4	5,5					60	58,5	57	55,5	53,5	51,5	47,5	43,5	38,5	33,5	
B-NMD 40/180C-60/A	NMD 40/180C-60/A	5,5	7,5					68	67,5	66,5	65,5	64	63	59,5	57	50	47,5	
B-NMD 40/180B-60/A	NMD 40/180B-60/A	7,5	10					86,5	86	84,5	83,5	82	80	77,5	74	68	65,5	58*
B-NMD 40/180A-60/A	NMD 40/180A-60/A	9,2	12,5					93,5	92,5	91,5	90,5	89	87	84,5	83	75,5	73,5	66*

B-NM	NM	P ₂		Q m³/h l/min	21	24	27	30	33	37,8	42	48	54	60	66	75	84	96
		kW	HP		350	400	450	500	550	630	700	800	900	1000	1100	1250	1400	1600
B-NM 17/H-60/A●	NM 17/H-60/A●	1,1	1,5	H m	9,2	9	8,7	8,5	8	7,5	6,5	5	3,5*					
B-NM 17/G-60/A●	NM 17/G-60/A●	1,5	2		12	11,8	11,6	11,5	11	10,5	9,5	8	6,5	4,5*				
B-NM 17/F-60/B	NM 17/F-60/B	2,2	3			16	15,8	15,5	15	14,5	14	12,7	11,5	10	8*			
B-NM 17/D-60/A	NM 17/D-60/A	3	4					18	17,7	17,5	17	16,5	15,5	14	12,5	11*		

NM, NMD Standard construction.
Ejecución normal.

B-NM, B-NMD Bronze construction.
Ejecución en bronce.

P₂ Rated motor power output.
Potencia nominal del motor.

H Total head in m.
Altura total en m.

- With single-phase motor = NMM - NMDM.
Con motor monofásico = NMM - NMDM.
- * Maximum suction lift 1-2 m.
Altura máxima de aspiración manométrica 1-2 m.
Tolerances according to UNI EN ISO 9906:2012.
Tolerancias según UNI EN ISO 9906:2012.

Rated currents - Intensidades nominales

	P ₂		single-phase - monofásico 1~				I _A /I _N
	kW	HP	220V I _N A	127V I _N A	110V I _N A	110/220V I _N A	
*	0,37	0,5	3,4	5,9	6,8	-	2,7
NMM 1/S-60	0,45	0,6	4,2	7,3	8,4	-	2,6
*	0,45	0,6	4,1	7,1	8,2	7.1/3.8	2,5
*	0,55	0,75	5,2	9	10,4	9.2/4.7	3,1
NMM 10/FE-60	0,55	0,75	6,5	11,3	13	-	2,9
NMM 25/12A-60	0,75	1	6,5	11,3	13	12.5/6.4	2,9
*	0,75	1	6,9	12	13,8	12.5/6.4	2,9
NMM 10/DE-60	0,75	1	6,5	11,3	13	-	2,9
NMM 20/160BE-60							
*	1,1	1,5	8,5	14,7	-	-	3
*	1,5	2	11	-	-	-	3,8
*	1,8	2,5	13,5	-	-	-	4,5

	P ₂		three-phase - trifásico 3~				I _A /I _N
	kW	HP	220/380V I _N A	380/660V I _N A	220/440V I _N A	I _A /I _N	
*	0,37	0,5	3/1,7	-	3,1/1,8	3,8	
*	0,45	0,6	2,6/1,5	-	2,7/1,6	3,5	
*	0,55	0,75	3,3/1,9	-	3,5/2	4,3	
NM 10/FE-60	0,55	0,75	4,5/2,6	-	4,7/2,7	5,2	
*	0,75	1	4,8/2,8	-	5/2,9	6	
NM 10/DE-60	0,75	1	4,5/2,6	-	4,7/2,7	5,6	
NM 20/160BE-60							
*	1,1	1,5	5,7/3,3	-	6,0/3,5	5,4	
*	1,5	2	9/5,2	-	9,4/5,5	5	
*	2,2	3	11,1/6,4	-	11,6/6,7	9	
*	3	4	13,4/7,7	-	14,0/8,1	8,4	
*	4	5,5		11,2/6,5		9,2	
*	5,5	7,5		13,7/7,9		8,7	
*	7,5	10		17/9,8		9,2	
*	9,2	12,5		22/12,7		8,3	

* For all types.

Para todos los tipos.

P₂ Rated motor power output.
Potencia nominal del motor.

I_A/I_N D.O.L. starting current / Rated current
Intensidad de arranque / Intensidad nominal

Characteristic curves - Curvas Características

$n \approx 3450$ rpm

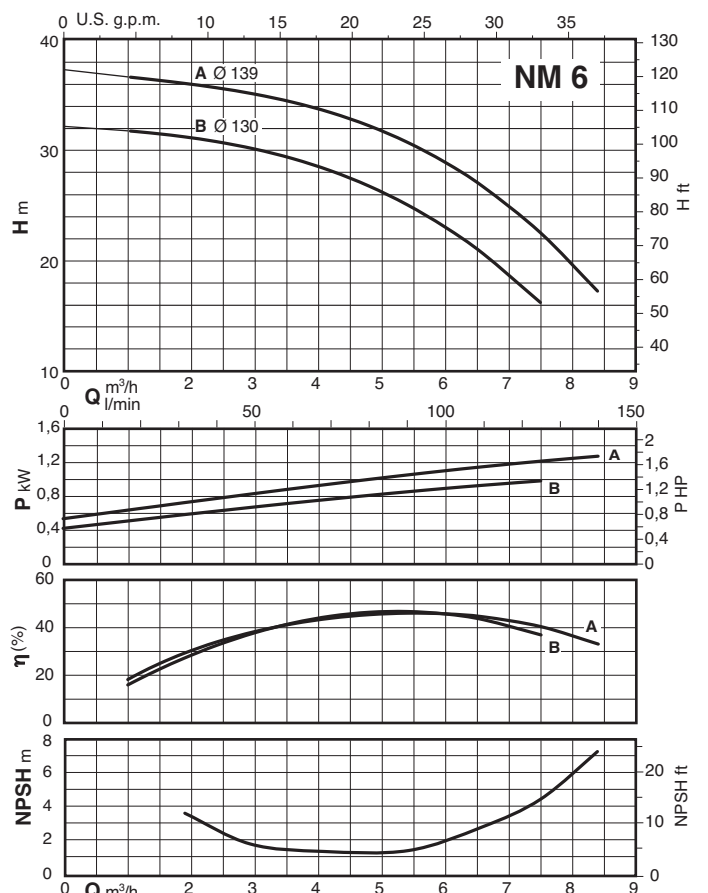
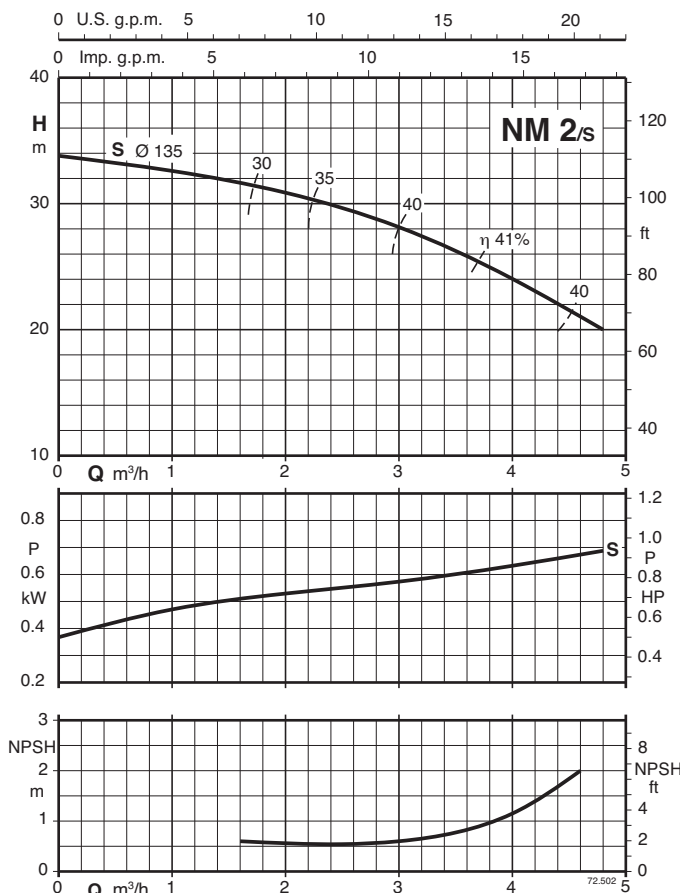
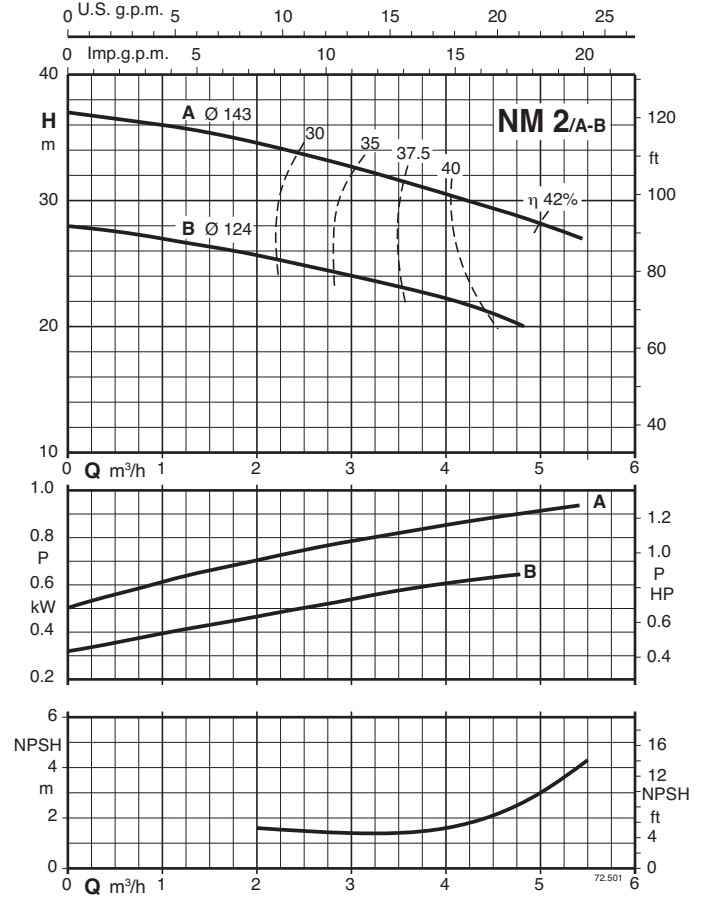
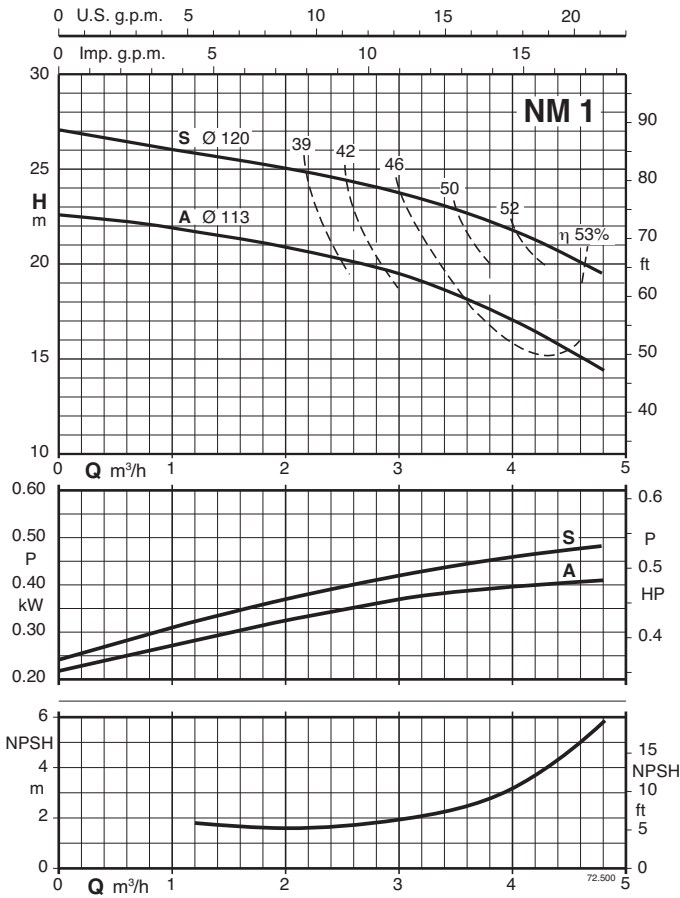

Characteristic curves - Curvas Características

$n \approx 3450$ rpm

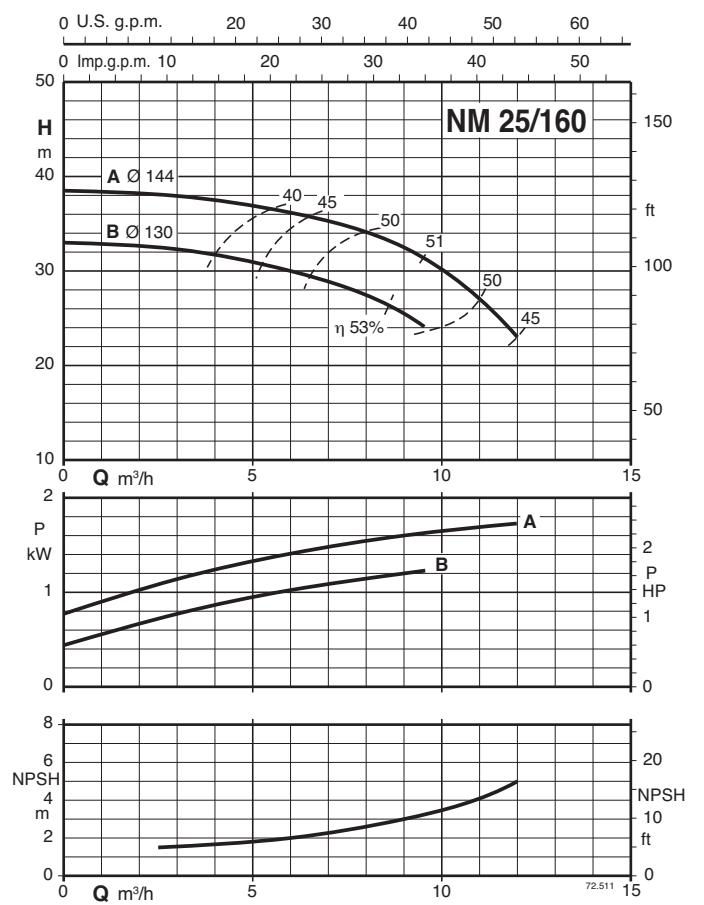
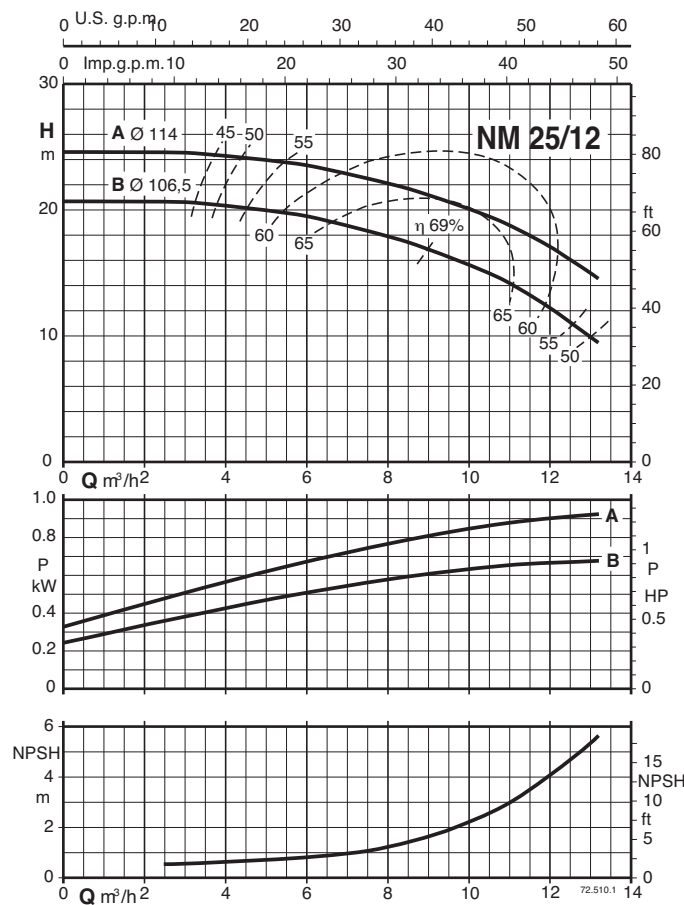
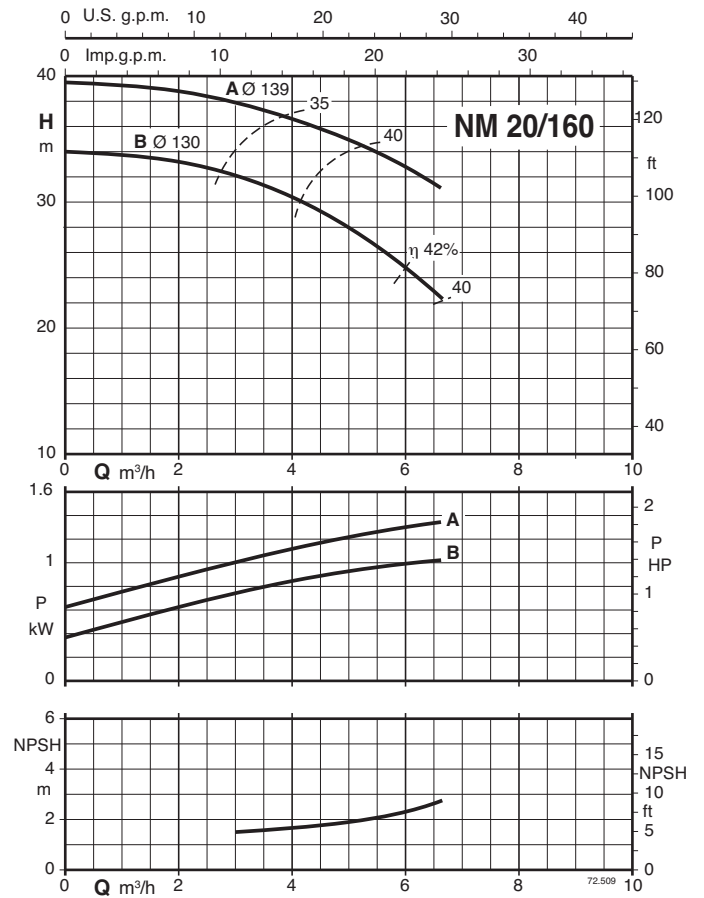
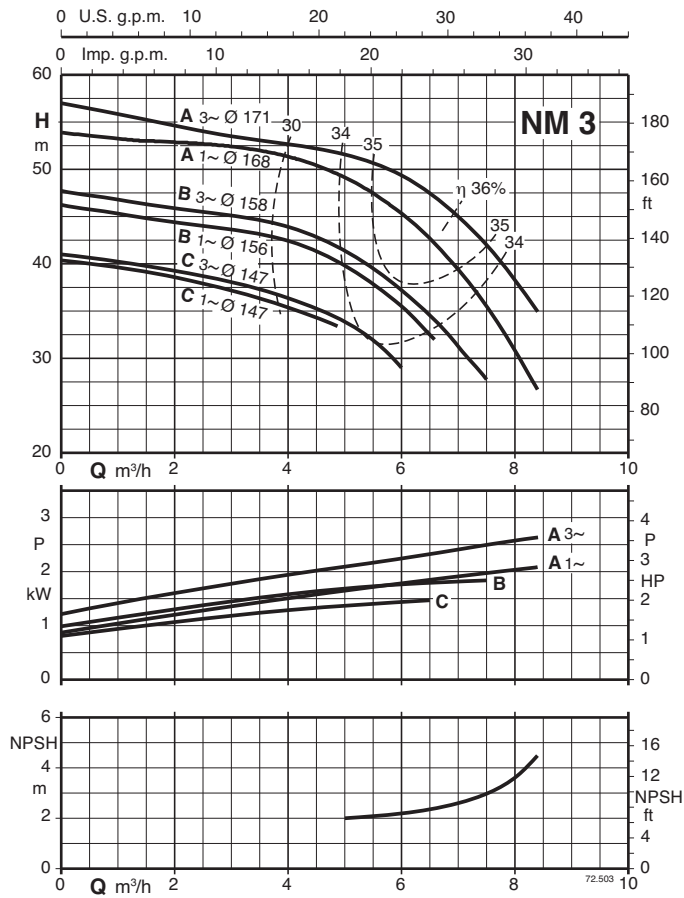

Characteristic curves - Curvas Características

$n \approx 3450$ rpm

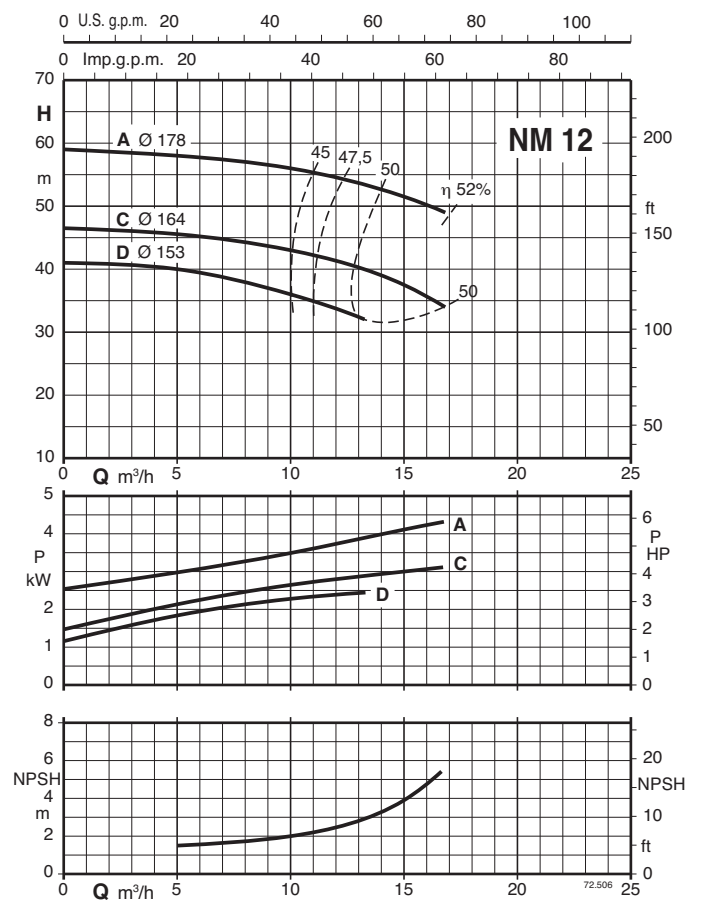
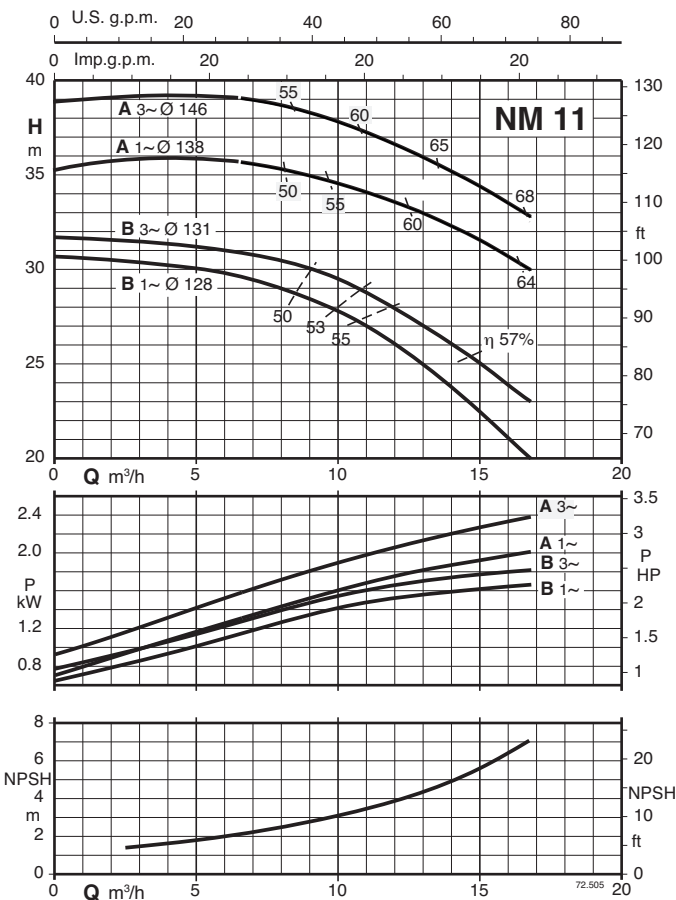
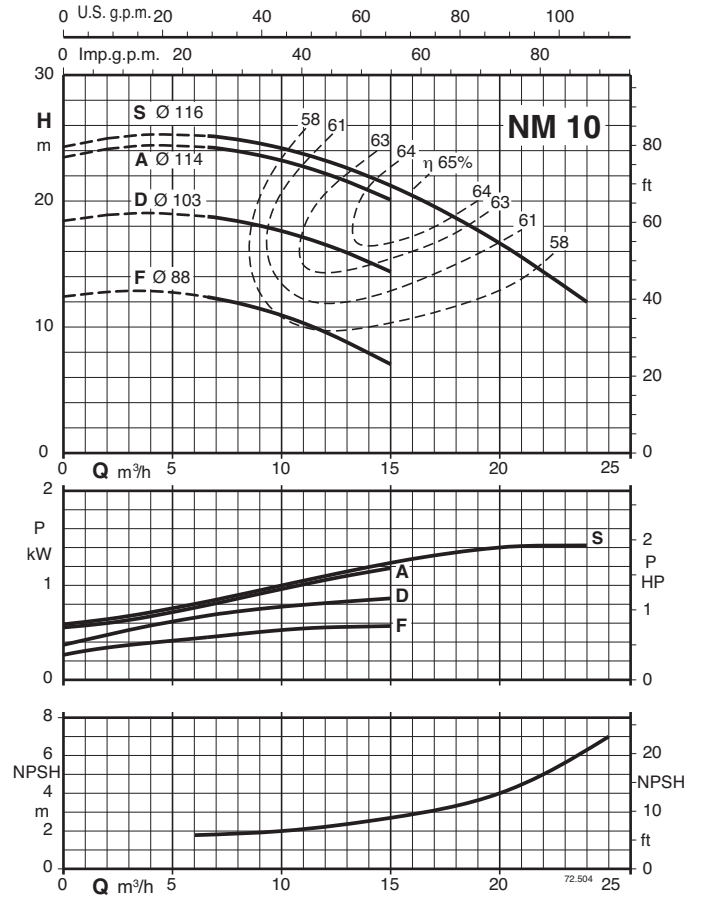
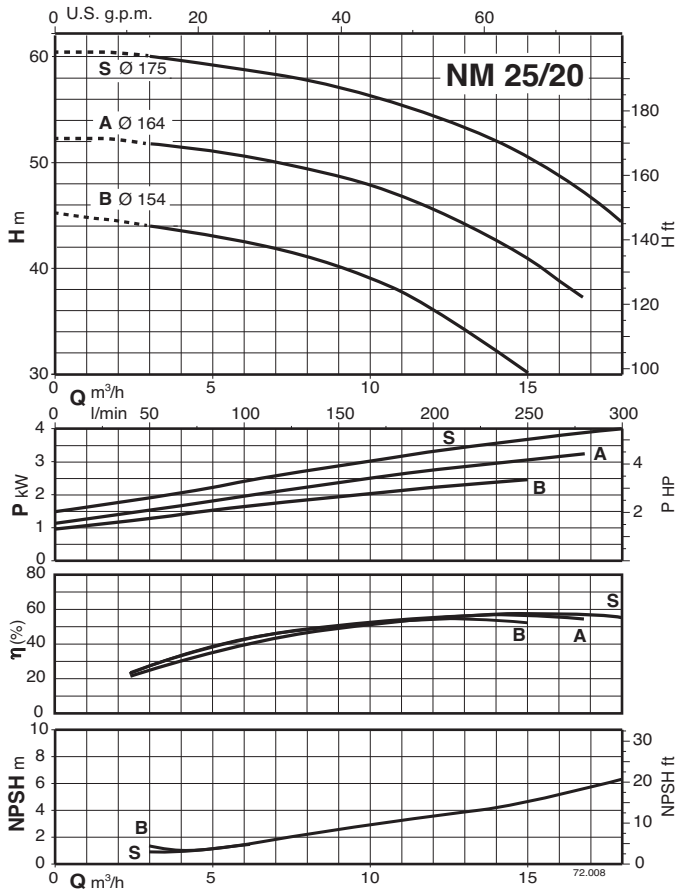

Characteristic curves - Curvas Características

$n \approx 3450$ rpm

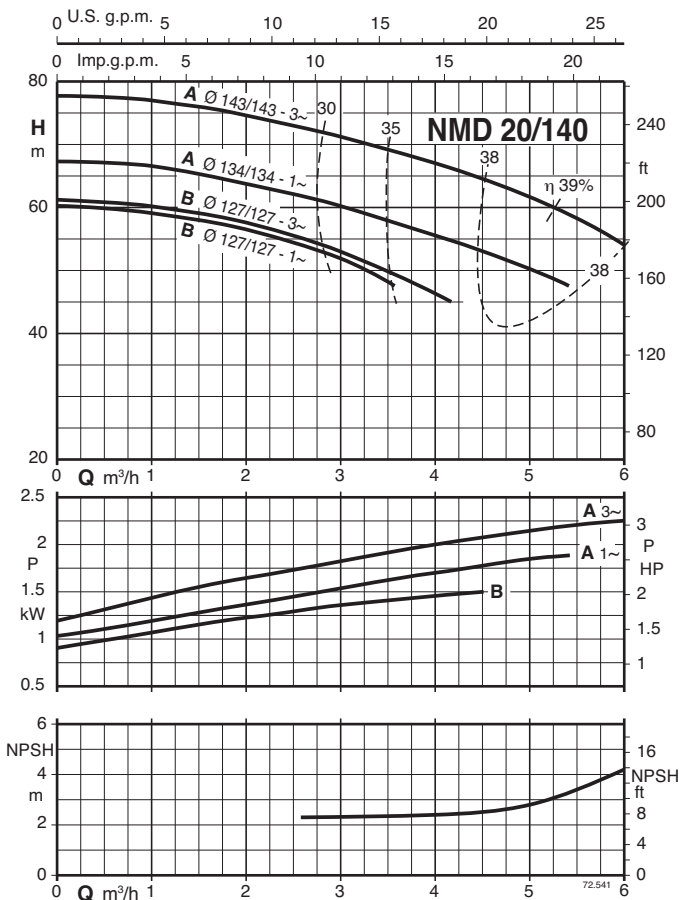
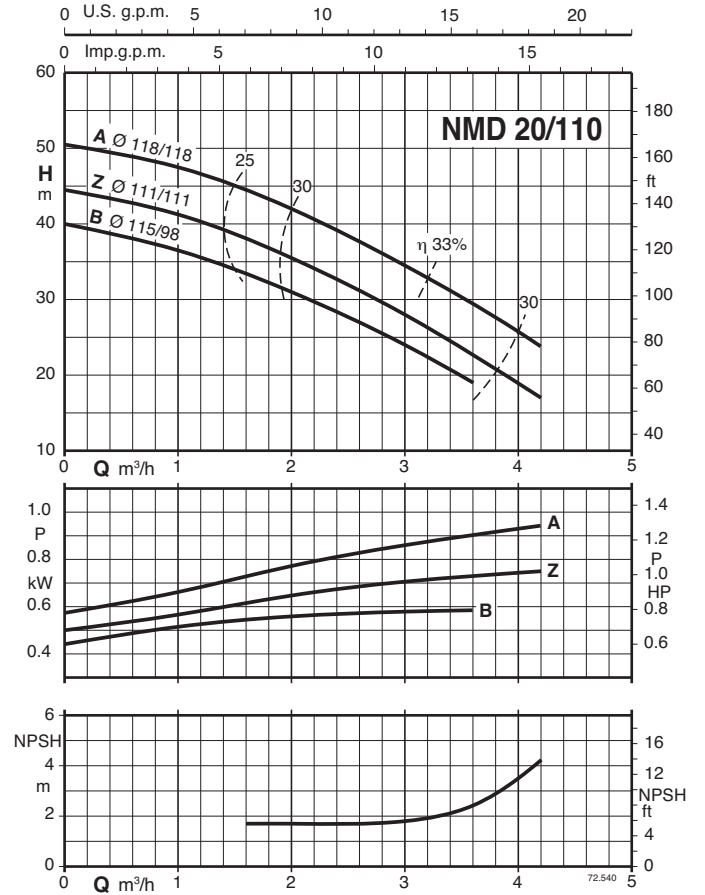
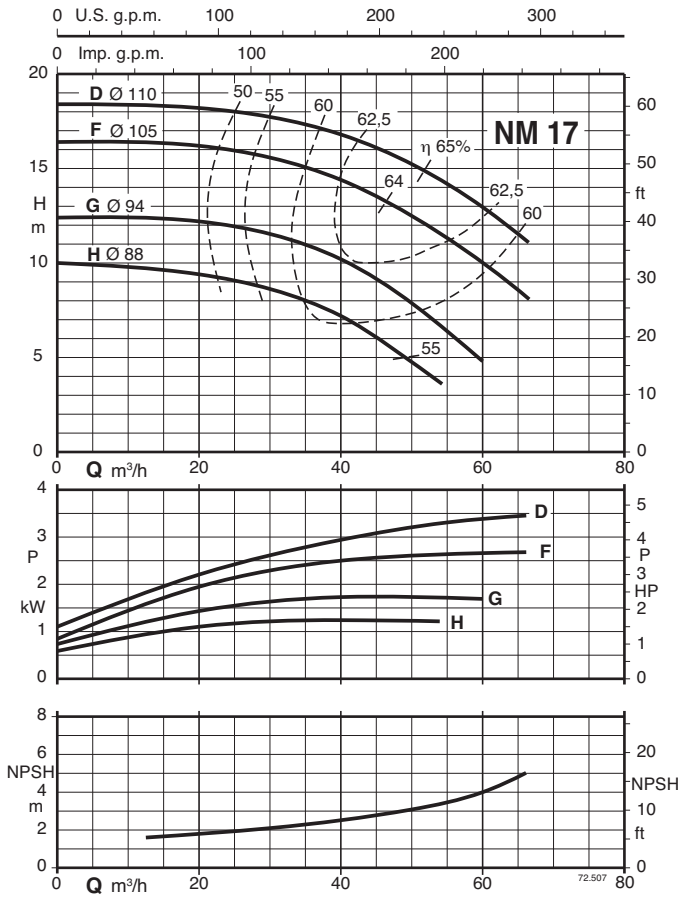

Characteristic curves - Curvas Características

$n \approx 3450$ rpm

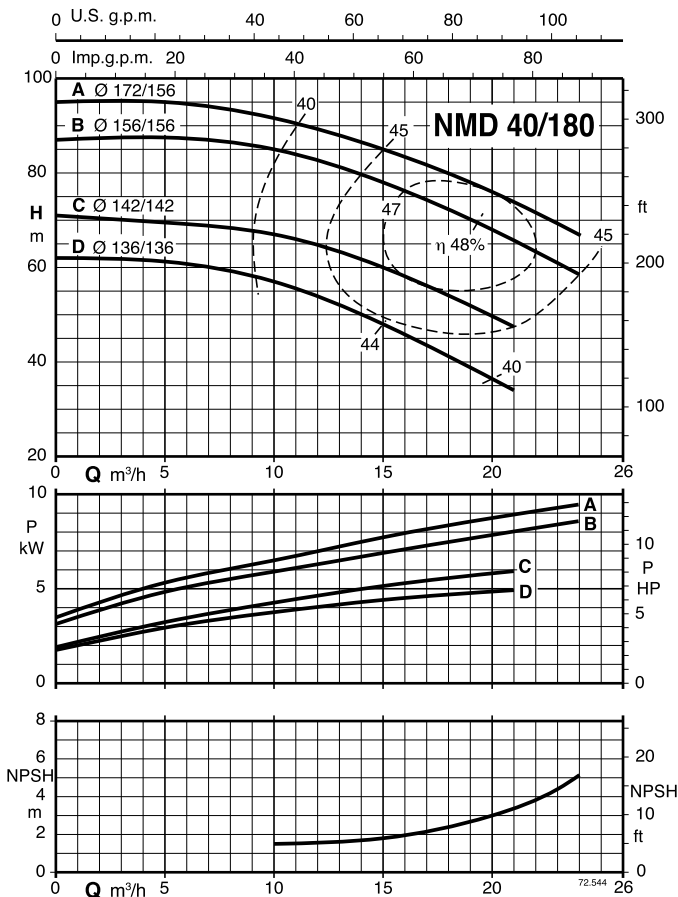
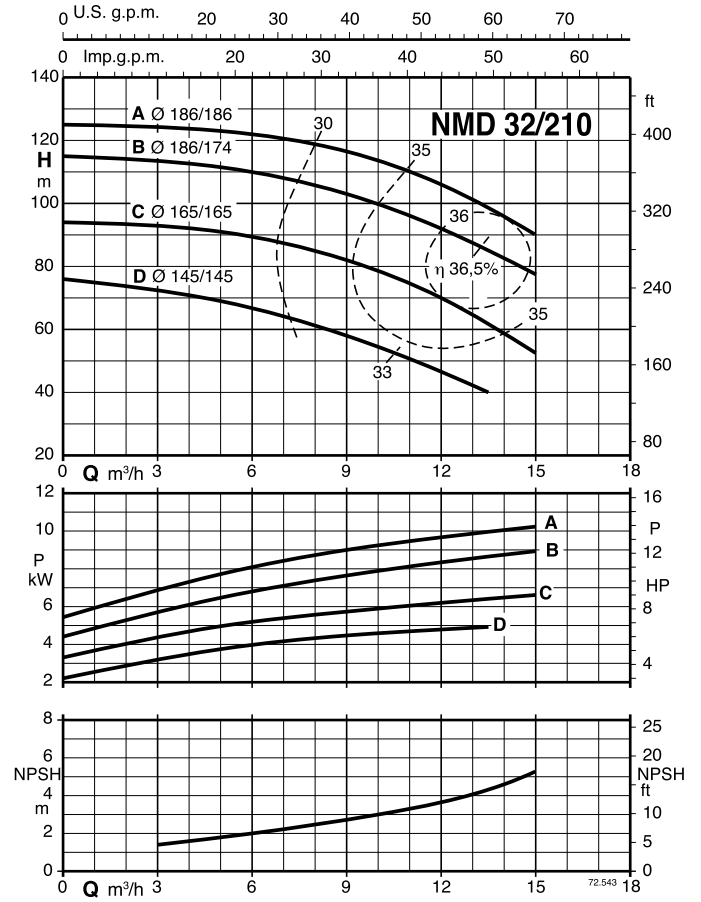
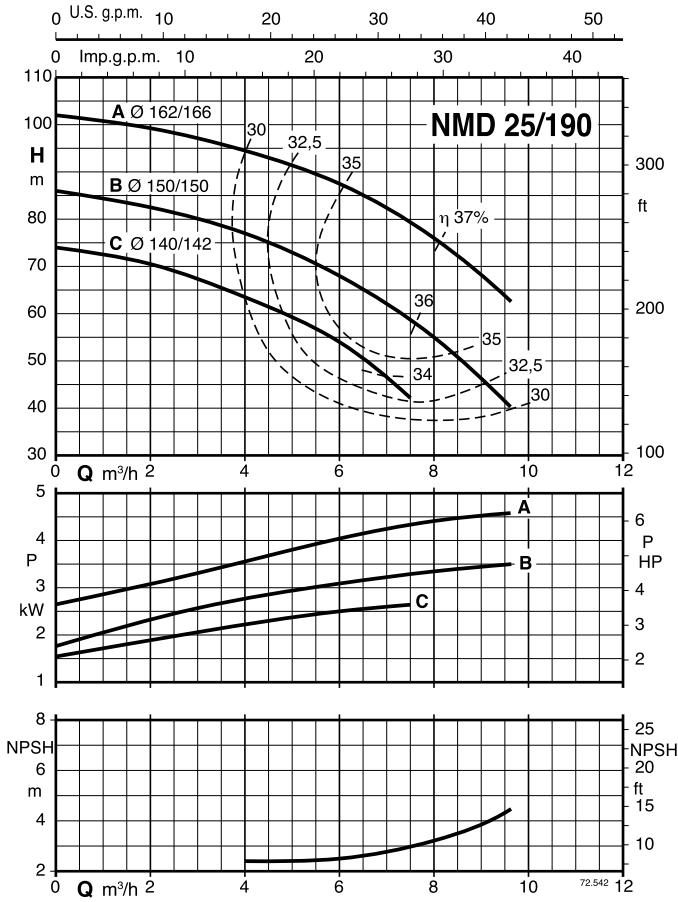

Dimensions and weights - Dimensiones y pesos

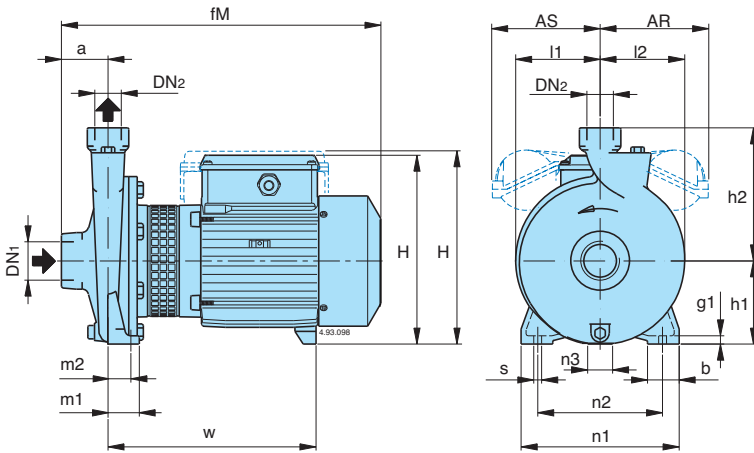

	H	AS mm				AR mm			
		220V	127V	110V	110/220V	220V	127V	110V	110/220V
NMM 1/AE-60	181	●	●	●	□	-	-	-	-
NMM 1/S-60	181	●	●	●	□	-	-	-	-
NMM 2/B-60/A	212	-	-	-	-	-	-	●	116
NMM 2/S-60/A	212	-	-	-	-	●	●	●	116
NMM 2/A-60/A	212	-	-	-	-	●	116	116	131
NMM 6/B-60	218	-	-	-	-	●	131	131	□
NMM 6/A-60	218	-	-	-	-	●	131	□	□
NMM 3/CE-60	245	●	131	□	□	-	-	-	-
NMM 3/BE-60	245	●	□	□	□	-	-	-	-
NMM 3/A-60/A	245	131	□	□	□	-	-	-	-
B- NMM 20/160BE-60	233	●	131	131	□	-	-	-	-
B- NMM 20/160AE-60	233	●	131	□	□	-	-	-	-
B- NMM 25/12B-60/A	204	-	-	-	-	●	●	●	116
B- NMM 25/12A-60/A	204	-	-	-	-	●	116	116	131
B- NMM 25/160BE-60	233	●	131	□	□	-	-	-	-
B- NMM 25/160AE-60	233	●	□	□	□	-	-	-	-
NMM 10/FE-60	233	●	116	131	□	-	-	-	-
NMM 10/DE-60	233	●	116	131	□	-	-	-	-
NMM 10/AE-60	233	●	131	□	□	-	-	-	-
NMM 10/SE-60	233	●	□	□	□	-	-	-	-
NMM 11/BE-60	245	●	131	□	□	-	-	-	-
B- NMM 17/HE-60	245	●	131	□	□	-	-	-	-
B- NMM 17/GE-60	245	●	□	□	□	-	-	-	-

● Standard dimensions - Dimensiones estándar
 □ Cannot be constructed - Non factibles

	NMM	NM	B-NM
	kg	kg	kg
NM 1/AE-60	8,7	8,6	
NM 1/S-60	9,3	9,2	
NM 2/B-60/A	14	13,1	
NM 2/S-60/A	14,2	13,3	
NM 2/A-60/B	15,1	15	
NM 6/B-60	17,8	17,6	
NM 6/A-60	19,3	19	
NM 3/C-60/A	24	22,9	
NM 3/B-60/A	26	25,1	
NM 3/A-60/B	30,4	29,1	
B- NMM 20/160BE-60	19,9	18,4	21
B- NMM 20/160A-60/A	20,7	19,7	22,5
B- NMM 25/12B-60/A	13,2	12,3	13,5
B- NMM 25/12A-60/B	14,2	14,1	14,5
B- NMM 25/160B-60/A	20,4	19,7	22,8
B- NMM 25/160A-60/A	22,5	21,5	24
NM 25/20B-60/C		31,6	
NM 25/20A-60/B		40,9	
NM 25/20S-60/C		42,2	
B- NMM 25/200B-60/C			35,7
B- NMM 25/200A-60/C			43,7
B- NMM 25/200S-60/C			45,2
NM 10/FE-60	19,3	18,5	
NM 10/DE-60	19,4	18,8	
NM 10/A-60/A	20,2	19,3	
NM 10/S-60/A	22,1	21,5	
NM 11/B-60/A	24,7	24,1	
NM 11/A-60/B		28,1	
NM 12/D-60/B		33,5	
NM 12/C-60/A		42	
NM 12/A-60/B		43,5	
B- NMM 17/H-60/A	23	22,2	29,2
B- NMM 17/G-60/A	24,2	23,2	30,2
B- NMM 17/F-60/B		28,2	35,2
B- NMM 17/D-60/A		36,2	43,2

B-NM	NM	DN1 ISO 228	DN2 NPT	mm																
				a	fM	h1	h2	H	m1	m2	n1	n2	n3	b	s	l1	l2	w	g1	
	NM 1/S-60,AE-60	G 1	G 1	✓	40	261	80	132	176	40	32	170	140	17	35	9,5	77	81	171	10
	NM 2/A-60/B,S-60/A,B-60/A	G 1	G 1	✓	45	305	95	150	207	40	32	190	160	17	35	9,5	87	90	203	10
	NM 6/A-60,B-60	G 1 1/4	G 3/4	✓	53	349	100	150	213	37,5	27,5	190	150	17	38	9,5	102	102	225	10
	NM 3/B-60/A,C-60/A	G 1	G 1	✓	50	375	112	180	240	55	43	245	205	37	45	11,5	110	113	244	12
	NM 3/A-60/B	G 1	G 1	✓	50	415	112	180	240	55	43	245	205	37	45	11,5	110	113	284	12
B- NMM 20/160A-60/A,BE-60	NM 20/160A-60/A,BE-60	G 1 1/4	G 3/4	✓	53	375	100	150	228	37,5	27,5	190	150	30	38	9,5	102	102	246	10
B- NMM 25/12A-60/B,B-60/A	NM 25/12A-60/B,B-60/A	G 1 1/2	G 1	✓	56	313	90	140	199	37,5	27,5	170	130	9	38	9,5	85	88	195	10
B- NMM 25/160A-60/A,B-60/A	NM 25/160A-60/A,B-60/A	G 1 1/2	G 1	✓	56	380	100	160	228	37,5	27,5	190	150	30	38	9,5	102	102	246	10
	NM 25/20B-60/C	G 1 1/2	G 1	✓	63	433	125	180	253	45	32,5	245	200	49	45	11,5	125	125	291	11
	NM 25/20A-60/B,S-60/C	G 1 1/2	G 1	✓	63	460	125	180	263	45	32,5	245	200	42	45	11,5	125	125	295	11
B- NMM 25/200B-60/C		G 1 1/2	G 1	✓	63	445	125	180	253	45	32,5	245	200	49	45	11,5	125	125	303	11
B- NMM 25/200A-60/B,S-60/C		G 1 1/2	G 1	✓	63	460	125	180	263	45	32,5	245	200	42	45	11,5	125	125	295	11
	NM 10/S-60/A,A-60/A,DE-60,FE-60	G 2	G 1 1/4	✓	63	382	100	150	228	50	35	190	140	30	50	13	90	97	239	14
	NM 11/B-60/A	G 2	G 1 1/4	✓	70	400	112	170	240	50	35	210	160	37	50	15	103	110	247	14
	NM 11/A-60/B	G 2	G 1 1/4	✓	70	440	112	170	240	50	35	210	160	37	50	15	103	110	287	14
	NM 12/D-60/B	G 2	G 1 1/4	✓	70	440	132	190	260	50	35	240	190	47	50	15	125	127	287	14
	NM 12/A-60/B,C-60/A	G 2	G 1 1/4	✓	70	470	132	190	270	50	35	240	190	45	50	15	125	127	300	14
B- NMM 17/G-60/A,H-60/A	NM 17/G-60/A,H-60/A	G 2 1/2	G 2 1/2	✓	80	417	112	160	240	50	35	210	160	37	50	14	96	113	257	14
B- NMM 17/F-60/B	NM 17/F-60/B	G 2 1/2	G 2 1/2	✓	80	463	112	160	240	50	35	210	160	37	50	14	96	113	304	14
B- NMM 17/D-60/A	NM 17/D-60/A	G 2 1/2	G 2 1/2	✓	80	480	112	160	250	50	35	210	160	20	50	14	96	113	295	14

✓ NPT Version on demand - Ejecuciones bajo demanda

Dimensions and weights - Dimensiones y pesos

NMD 20/110

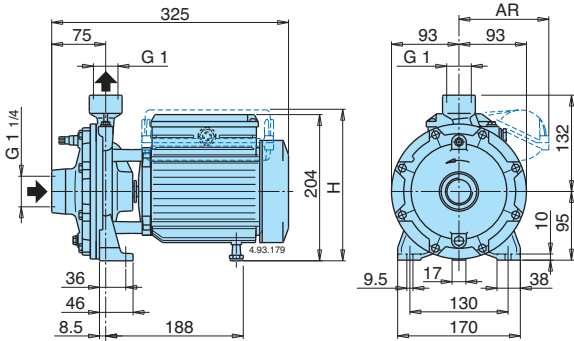

	NMDM	NMD	B-NMD
	kg	kg	kg
B- NMD 20/110B-60/A	13	12,1	13,4
B- NMD 20/110Z-60/A	14	13	14,2
B- NMD 20/110A-60/B	15,1	15	17,4

	H	AR mm			
		220V	127V	110V	110/220V
B- NMDM 20/110B-60/A	209	●	●	●	116
B- NMDM 20/110Z-60/A	209	●	●	●	116
B- NMDM 20/110A-60/A	209	●	116	116	131

● Standard dimensions - Dimensiones estándar

NMD 20/140, NMD 25/190

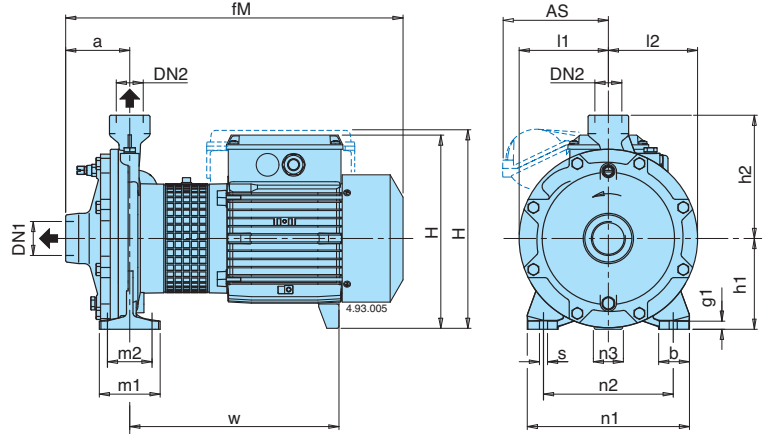

	NMDM	NMD	B-NMD
	kg	kg	kg
B- NMD 20/140B-60/A	23,9	22,7	25,2
B- NMD 20/140A-60/A	25,2	24,8	27,6
B- NMD 25/190C-60/B		42	45,7
B- NMD 25/190B-60/A		49,7	54
B- NMD 25/190A-60/B		51,5	55,5

	H	AS mm			
		220V	127V	110V	110/220V
B- NMDM 20/140BE-60/A	248	●	131	131	□
B- NMDM 20/140AE-60/A	248	●	131	□	□

● Standard dimensions - Dimensiones estándar □ Cannot constructed - Non fatibles

B-NMD	NMD	DN1	DN2	ISO 228	NPT	mm															
						a	fM	h1	h2	H	m1	m2	n1	n2	n3	b	s	l1	l2	w	g1
B-NMD 20/140A-60/A,B-60/A	NMD 20/140A-60/A,B-60/A	G 1 1/4	G 1	✓	80	417	112	152	243	75	55	200	160	37	38	9,5	110	110	256	10	
B-NMD 25/190C-60/B	NMD 25/190C-60/B	G 1 1/2	G 1	✓	97	487	140	180	268	100	70	240	190	50	49	50	14	133	133	314	13
B-NMD 25/190A-60/B,B-60/B	NMD 25/190A-60/B,B-60/B					500			278											306	

NMD 32/210, NMD 40/180

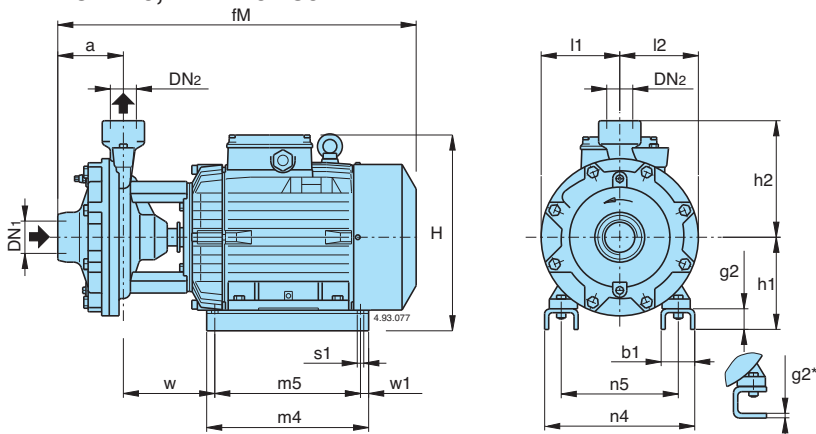

	NMD	B-NMD
	kg	kg
B- NMD 32/210D-60/B	60,5	66,5
B- NMD 32/210C-60/A	71	77
B- NMD 32/210B-60/A	77	82,5
B- NMD 32/210A-60/A	99	105
B- NMD 40/180D-60/B	59,5	65,5
B- NMD 40/180C-60/A	70	76
B- NMD 40/180B-60/A	76	81,5
B- NMD 40/180A-60/A	97	102

B-NMD	NMD	DN1	DN2	ISO 228	NPT	mm														
						a	fM	h1	h2	H	m4	m5	n4	n5	w1	b1	s1	l1	l2	w
B-NMD 32/210D-60/B	NMD 32/210D-60/B						530	155	293	205	175	194	140		54	10			139	6*
B-NMD 32/210B-60/A,C-60/A	NMD 32/210B-60/A,C-60/A	G 2	G 1 1/4	✓	110	550	150	215	310	280	250	258	190	15	68	12	150	150	108	38
B-NMD 32/210A-60/A	NMD 32/210A-60/A					625	170		355	298	268	286	216		70	12			152	38
B-NMD 40/180D-60/B	NMD 40/180D-60/B					535	155		293	205	175	194	140		54	10			133	6*
B-NMD 40/180B-60/A,C-60/A	NMD 40/180B-60/A,C-60/A	G 2	G 1 1/2	✓	121	555	150	215	310	280	250	258	190	15	68	12	145	145	102	38
B-NMD 40/180A-60/A	NMD 40/180A-60/A					630	170		355	298	268	286	216		70	12			145	38*

✓ NPT Version on demand - Ejecuciones bajo demanda

Features - Características constructivas

Compact Design

The compact design allows for easy installation even in confined spaces.

Robustness

The mechanical structure of the hydraulic parts in contact with the pumped liquid are dimensioned to guarantee the maximum resistance to mechanical stress.

A unique design

The lantern bracket design prevents contact with the pumps rotating parts, providing protection to the end user whilst allowing for inspection of the mechanical seal.

Reliability

The bearing and shaft are designed to ensure the reduction of the stress, providing high reliability under all operating conditions.

Diseño compacto

El diseño compacto permite una fácil instalación incluso en espacios reducidos.

Robustez

La estructura mecánica de las partes hidráulicas en contacto con el líquido bombeado están dimensionadas para garantizar la máxima resistencia a la tensión mecánica.

Diseño exclusivo

Un innovador protector patentado evita el contacto con las partes rotantes, lo que demuestra la protección para el usuario final mientras le permite la inspección del sello mecánico.

Fiabilidad

El cojinete y el eje están diseñados para asegurar la reducción de la tensión, proporcionando alta fiabilidad en todas las condiciones de funcionamiento.

Flexibility

The option to choose between cast iron and bronze materials for the hydraulic parts in contact with the pumped liquid allows NMD series pumps to be selected for use with different types of liquids.

Robustness

The mechanical structure of the hydraulic parts in contact with the pumped liquid are dimensioned to guarantee the maximum resistance to mechanical stress.

Reliability

The bearing and shaft are designed to ensure the reduction of the stress, providing high reliability under all operating conditions.

Flexibilidad

La opción de elegir entre el hierro fundido y Materias bronce para las partes hidráulicas en contacto con el líquido bombeado permite bombas de la serie NMD a ser seleccionadas para su uso con diferentes tipos de líquidos.

Robustez

La estructura mecánica de las partes hidráulicas en contacto con el líquido bombeado están dimensionadas para garantizar la máxima resistencia a la tensión mecánica.

Fiabilidad

El cojinete y el eje están diseñados para asegurar la reducción de la tensión, proporcionando alta fiabilidad en todas las condiciones de funcionamiento.

NM

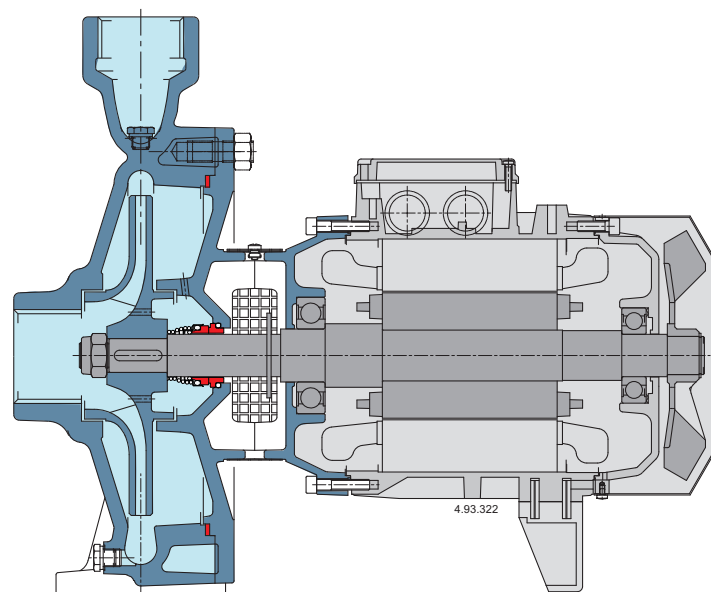

NMD

