

PATENTED



Materials

Component	Material
Pump casing Impeller	Cast iron GJL 200 EN 1561
Strainer Motor jacket Jacket cover Casing cover	Chrome-nickel steel 1.4301 EN 10088 (AISI 304)
Handle	Polypropylene (with frame in AISI 304)
Shaft	Chrome-nickel steel 1.4301 EN 10088 (AISI 304)
Mechanical seal: upper lower	Ceramic alumina/Carbon/NBR
Seal lubrication oil	Oil for food/pharmaceutical machinery

Construction

Single-impeller submersible drainage pump, with open impeller.

GQR: with vertical threaded delivery port (G 1 1/2).

GQR 10 32: with horizontal flanged and threaded delivery port (DN 32, PN 6 - G 1 1/2).

Double mechanical shaft seal with interposed oil chamber, to protect against dry-running.

Applications

For clean water containing solids up to 10 mm grain size.

For draining rooms or or emptying tanks.

Extraction of water from ponds, streams or pits and for rainwater collection.

For irrigation purposes.

Operating conditions

Liquid temperature up to 35° C.

Maximum immersion depth: 5 m.

Minimum immersion depth: 205 mm.

Continuous duty (with submerged motor).

Motor

2-pole induction motor, 50 Hz (n ≈ 2900 rpm).

GQR: three-phase 230 V ± 10%;

three-phase 400 V ± 10%;

Cable: H07RN-F, 4G1 mm², length 10 m, without plug.

GQRM: single-phase 230 V ± 10%,
with float switch and thermal protector.

Incorporated capacitor.

Cable: H07RN-F, 3G1 mm², length 10 m, with plug

CEI-UNEL 47166.

Insulation class F.

Protection IP X8 (for continuous immersion)

Triple impregnation humidity-proof dry winding.

Constructed in accordance with: EN 60034-1;

EN 60335-1, EN 60335-2-41.

Other features on request

- Other voltages. - Frequency 60 Hz (as per 60 Hz data sheet).
- Other mechanical seal.
- Cable length 20 m.
- Vertical magnetic float switch.
- Motor suitable for operation with frequency converter.
- Three-phase pumps with incorporated float switch.

Characteristic curves n ≈ 2900 rpm

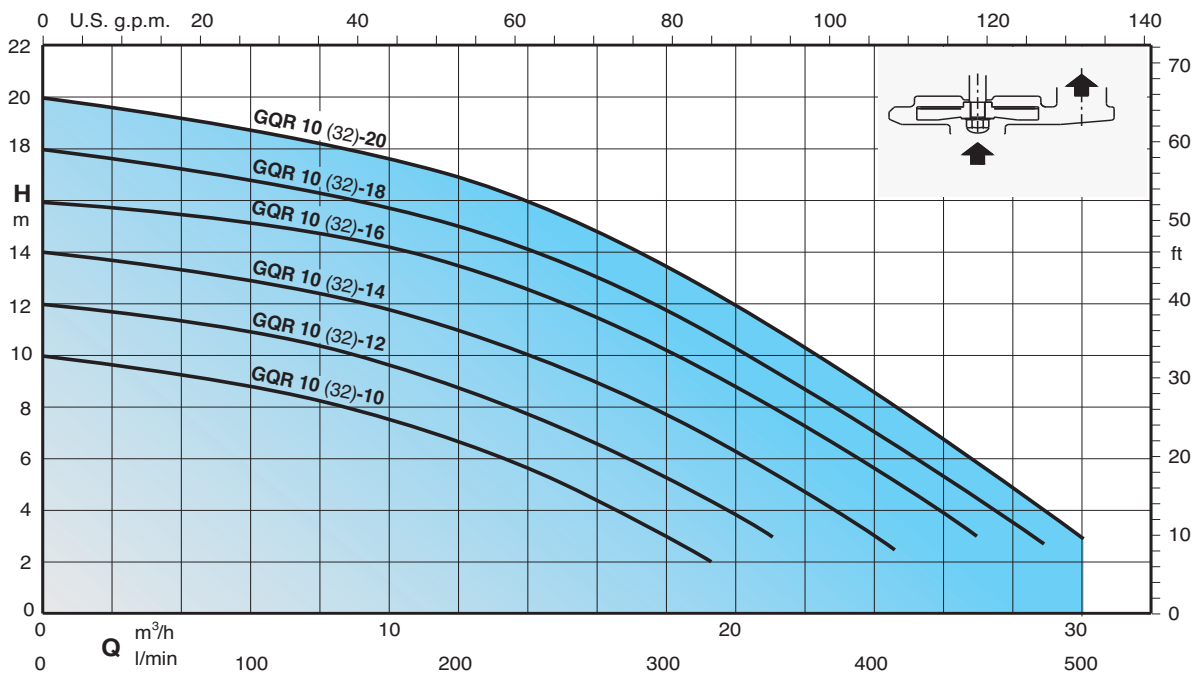

Performance $n \approx 2900$ rpm

3~	230V 400V		1~	230V	Capacitor		P1			P2			Q	H										
	A	A			A	μ f	Vc	kW	kW	HP	m ³ /h	0		3	6	9	12	15	18	21	24	27	30	
													l/min	0	50	100	150	200	250	300	350	400	450	500
GQR 10-10 GQR 10 32-10	2	1,2	GQRM 10-10 GQRM 10 32-10	3,1	12,5	450	0,7	0,45	0,6				10	9,5	8,8	8	6,7	5	3	-	-	-	-	-
GQR 10-12 GQR 10 32-12	2,4	1,4	GQRM 10-12 GQRM 10 32-12	3,6	16	450	1	0,55	0,75				12	11,6	11	10,2	9	7,5	5,5	3,2	-	-	-	-
GQR 10-14 GQR 10 32-14	2,8	1,6	GQRM 10-14 GQRM 10 32-14	4,6	16	450	1	0,75	1				14	13,5	12,8	12	10,8	9,3	7,5	5,5	3	-	-	-
GQR 10-16 GQR 10 32-16	4	2,3	GQRM 10-16 GQRM 10 32-16	6	25	450	1,3	0,9	1,2				16	15,5	15	14,2	13,2	11,8	10,2	8	5,5	2,3	-	-
GQR 10-18 GQR 10 32-18	4,8	2,8	GQRM 10-18 GQRM 10 32-18	8	30	450	1,7	1,1	1,5				18	17,5	17	16,2	15	13,7	11,8	9	7	4,3	-	-
GQR 10-20 GQR 10 32-20	6,6	3,8	GQRM 10-20 GQRM 10 32-20	13	35	450	2,2	1,5	2				20	19,5	18,8	18	16,8	15,2	13,2	10,8	8,4	5,7	3	-

P1 Max. power input.

P2 Rated motor power output.

Density $\rho = 1000$ kg/m³.

Kinematic viscosity $\nu = \max 20$ mm²/sec.

Dimensions and weights

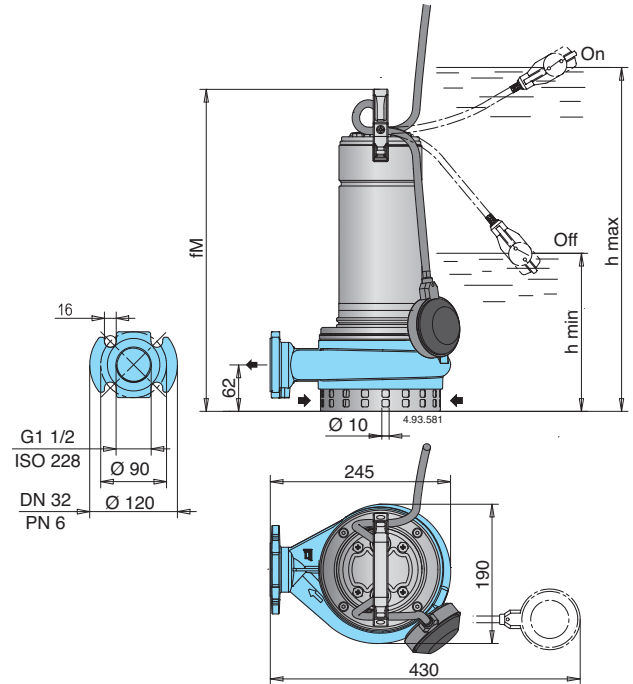
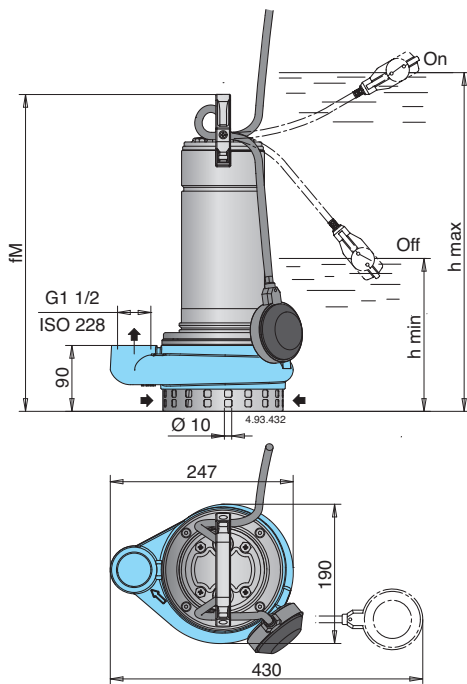

TYPE	mm			kg (1)	
	fM	h max	h min	GQR	GQRM
GQR(M) 10-10	390	410	205	14	15
GQR(M) 10-12	405	425	220	14,5	15,5
GQR(M) 10-14	405	425	220	14,5	15,5
GQR(M) 10-16	430	450	245	16	18
GQR(M) 10-18	450	470	265	17,5	19
GQR 10-20	450	470	265	19	-
GQRM 10-20	480	500	295	-	20,5

1) With cable length: 10 m

TYPE	mm			kg (1)	
	fM	h max	h min	GQR	GQRM
GQR(M) 10 32-10	395	415	210	14,7	15,7
GQR(M) 10 32-12	410	430	225	15,2	16,2
GQR(M) 10 32-14	410	430	225	15,2	16,2
GQR(M) 10 32-16	435	455	250	16,7	18,7
GQR(M) 10 32-18	455	475	270	18,2	19,7
GQR 10 32-20	455	475	270	19,7	-
GQRM 10 32-20	485	505	300	-	21,2

1) With cable length: 10 m

Installation examples

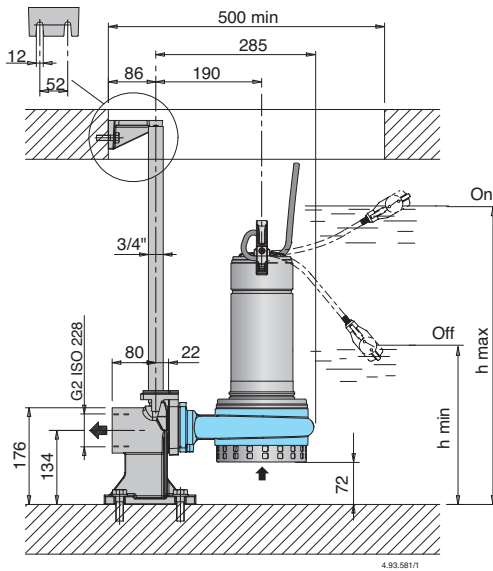

TYPE	mm	
	h max	h min
GQR(M) 10 32-10	487	282
GQR(M) 10 32-12	502	297
GQR(M) 10 32-14	502	297
GQR(M) 10 32-16	527	322
GQR(M) 10 32-18	547	342
GQR 10 32-20	547	342
GQRM 10 32-20	577	372

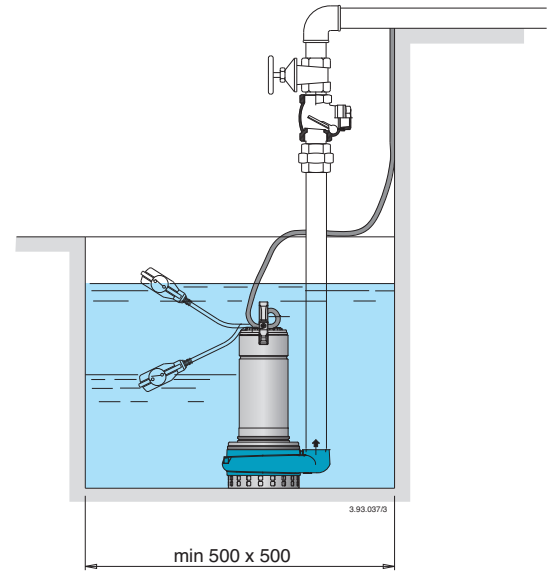

Installation examples with vertical magnetic float switch

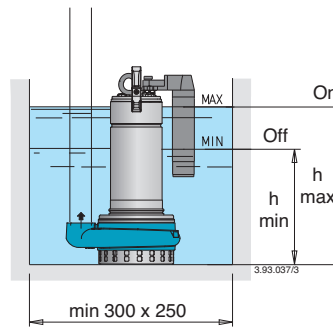
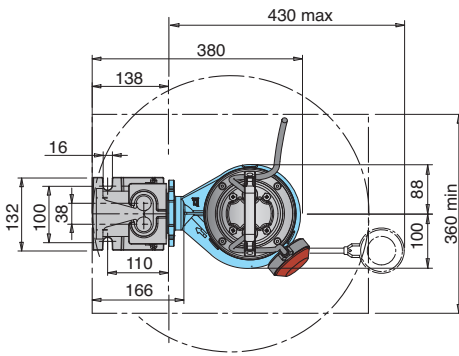

TYPE	mm	
	h min	h max
GQRM 10-10 GF	225	315
GQRM 10-12 GF	240	330
GQRM 10-14 GF	240	330
GQRM 10-16 GF	265	355
GQRM 10-18 GF	285	375

Installation examples

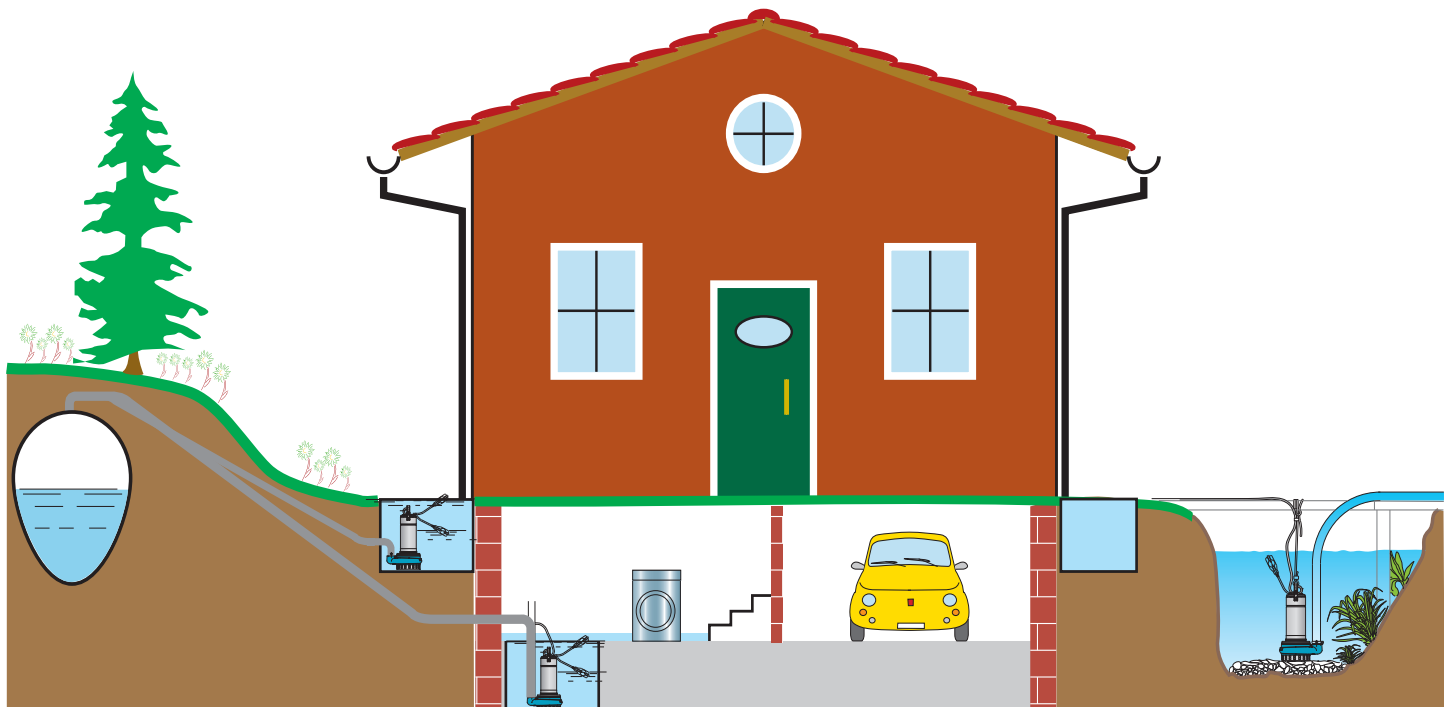

Features

PATENTED

Cable length 10 m, pump single-phase with plug

Handle in polypropylene, with frame in stainless steel.

Easy inspection of the capacitor area.

Easy adjustment of the float switch: to allow the adjustment of start/stop pump levels.

Ring against accidental extraction of the cable.

Relief valve: the pump is fitted to a relief valve for air release around the impeller granting a proper pump priming also after long standstill periods.

The double shaft seal with oil chamber separates the motor from the water and provides further protection against accidental operation when dry.

G 1 1/2 vertical, upward delivery port for installation in small pits, without the need for an elbow on the pump.

Chamber with food/pharmaceutical machinery oil

Shaft in chrome-nickel stainless steel.

Pump casing with epoxy cataphoresis treatment joined to the external paint for a greater protection against the rust.

Suction strainer with a double row of holes, for extra safety against clogging: it allows the passage of solids up to 10 mm.

Impeller with epoxy cataphoresis treatment for a greater protection against the rust.

Maximum flexibility of connection:

- Flange DN 32 PN 6 EN 1092-2 for duck foot coupling SA-G2"
- G1 1/2 ISO 228

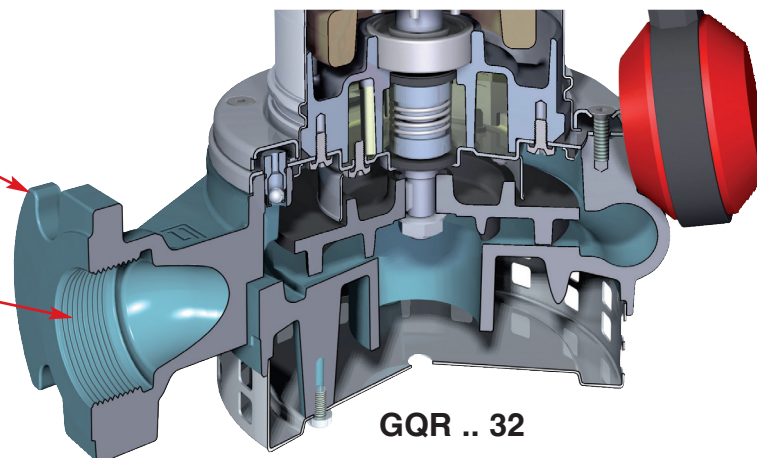

GQR .. 32