

NCE PS Energy saving circulating pumps for sanitary hot water



Construction

Energy saving variable speed circulating pump driven by a permanent magnet synchronous motor (pm) controlled by on board inverter. Bronze pump casing.

Applications

Sanitary hot water systems.

Operating conditions

- Liquid temperature from +5 °C to +65 °C
- Ambient temperature from 0 °C to +40 °C
- Maximum permissible working pressure: 10 bar
- Storage: -20°C/+70°C max. relative humidity 95% at 40 °C
- Certifications: in conformity with CE requirements
- Sound pressure \leq 38 dB (A).
- Minimum suction pressure: - 0,05 bar at 75 °C
- 0,28 bar a 90 °C.
- Maximum glycol quantity: 20%.
- EMC according to: EN 55014-1, EN 55014-2
EN 61000-3-2, EN 61000-3-2.
- Connections: threaded ports ISO 228: G 1 1/4, G 1 1/2.

Designation

NCE PS 25 - 60 / 180

Series _____
 Version for sanitary hot water _____
 DN ports in mm _____
 Max. head in dm _____
 connection size mm _____

Motor

Synchronous motor with permanent magnet.

- Motor: variable speed
- Standard voltage: single-phase 230 V (-10%;+6%)
- Frequency: 50-60 Hz
- Protection: IP 44
- Insulation class: F
- Overload protection (integrated).
- Cable: phases and neutral.
- Constructed in accordance with: EN 60335-1, EN 60335-2-51.

Special features on request

The NCE PSR version is equipped with an additional module that allows to control the pump with an analog signal 0-10V. Brass unions.

Features

Easy adjustment

The adjustment is simple and intuitive thanks to the LED indicator.

Easy use

3 proportional curves and 3 fixed speed curves are available and selectable by the button.

Operating modes

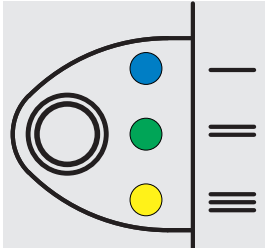

Operating functions - control buttons.

NCE PS circulator could work:
 - with proportional pressure curves
 - with fixed speed curves



PROPORTIONAL CURVE PROGRAMMING $\Delta p-v$

- (P1 BLUE LED blinking light)
- (P2 GREEN LED blinking light)
- (P3 YELLOW LED blinking light)

Push repeatedly the button to select the proportional curve.
 The color changes depending on the selected curve.
 This operating mode guarantees the maximum energy efficiency.



FIXED SPEED CURVE PROGRAMMING

- (I BLUE LED light)
- (II GREEN LED light)
- (III YELLOW LED light)

If you push the button for 5 seconds the pump adopt the fixed speed curve. The color changes depending on the selected curve. (to replace standard 3-speed circulators).

Coverage chart

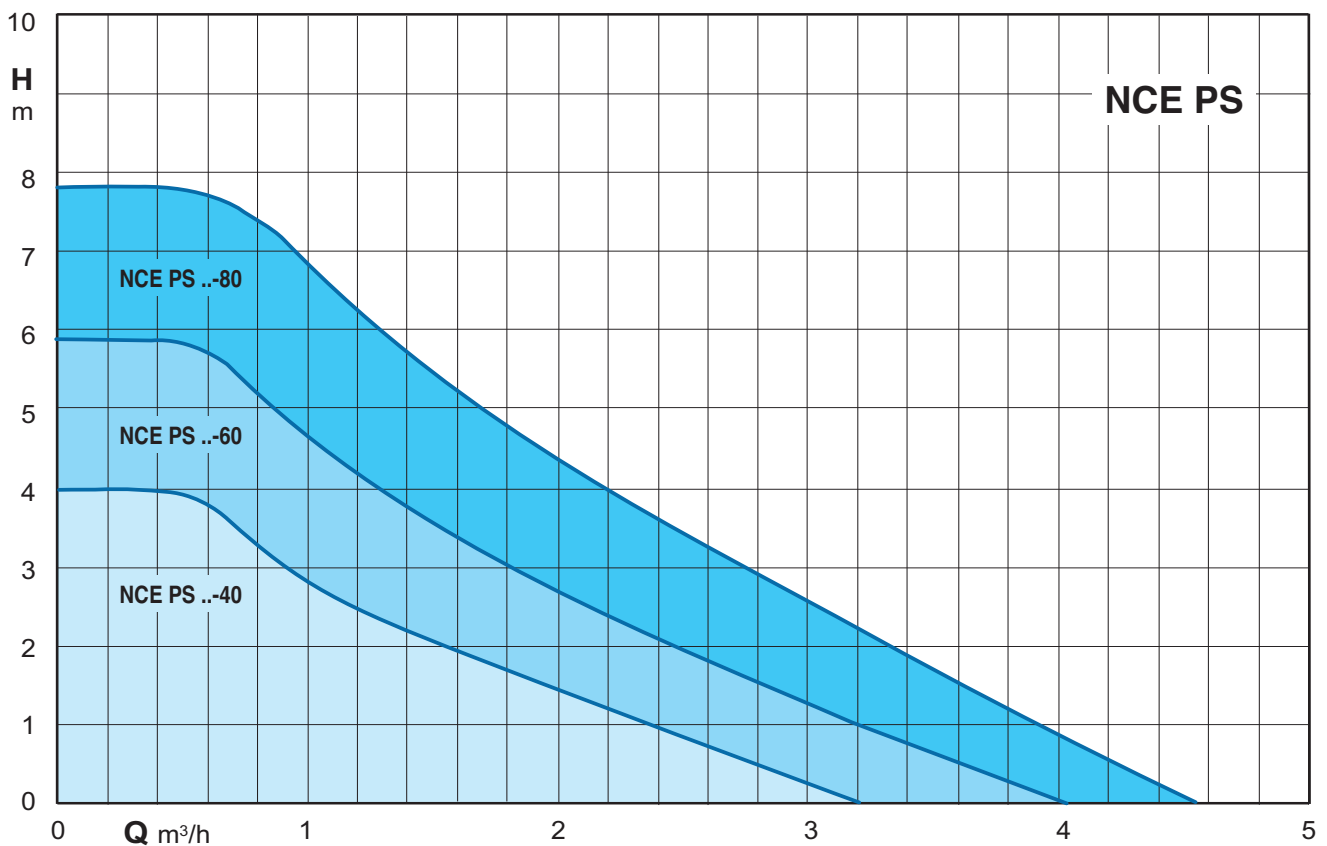

Characteristic curves

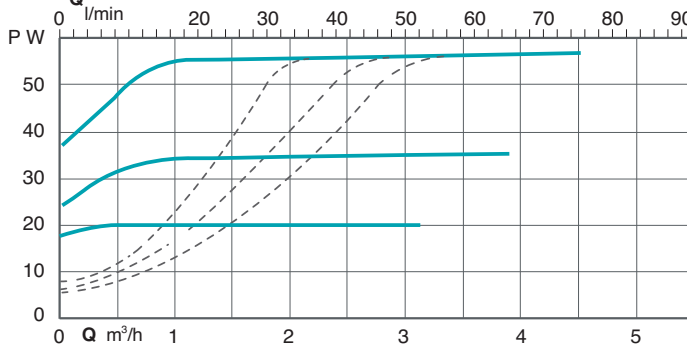
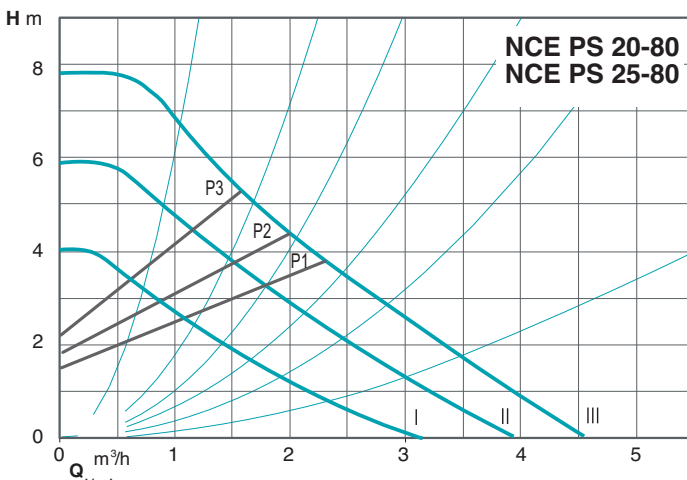
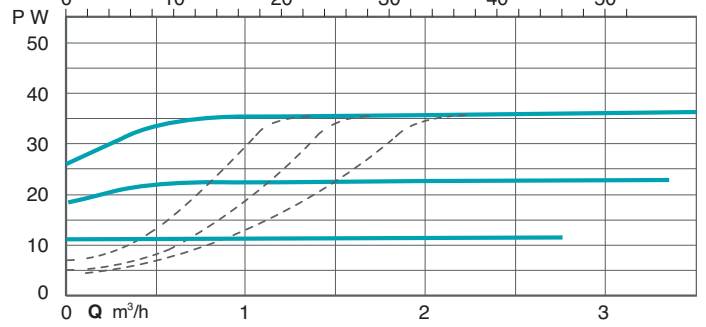
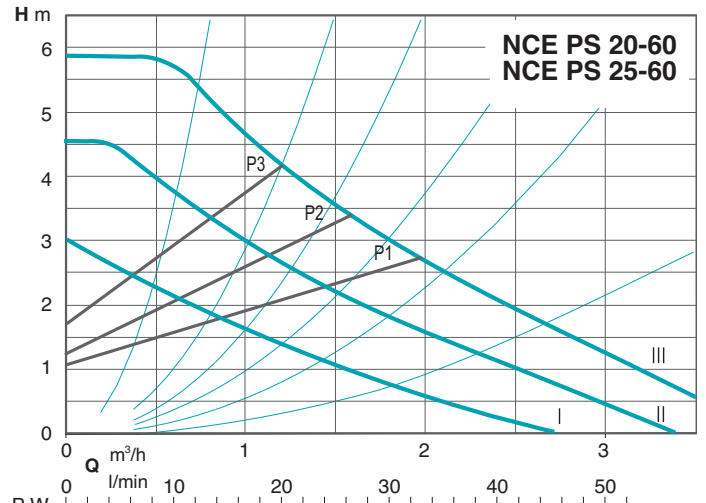
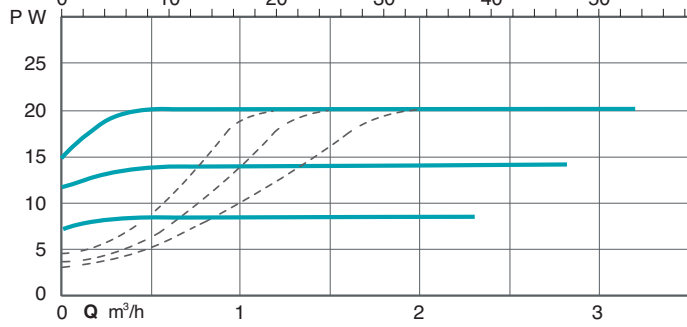
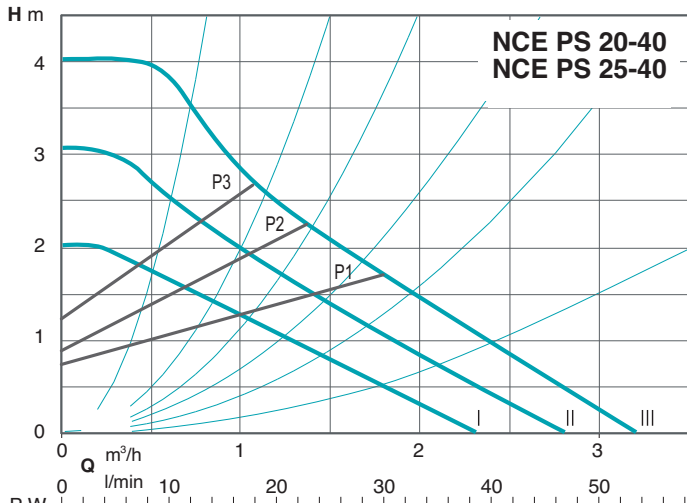

Materials

Component	Pos.	Material
Pump casing	1	Bronze
Impeller	2	Composite
Shaft	3	Stainless steel AISI 420
Bearings	4	Carbon
Thrust bearing	5	Ceramic
Rotor	6	Stainless steel jacket
Winding	7	Copper wire
Electronic card	8	-
Gasket	9	EPDM

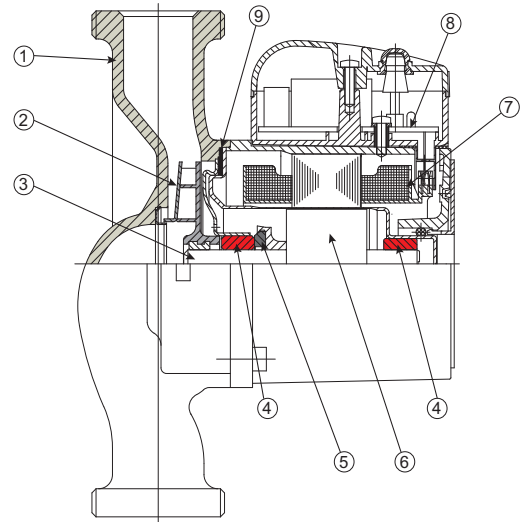

Examples of installations

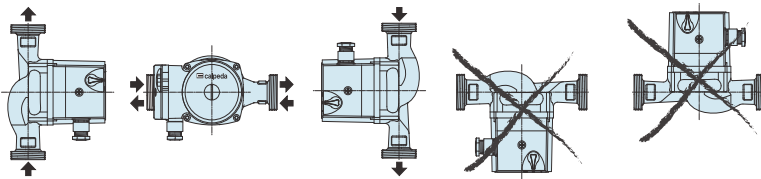

Dimensions and weights

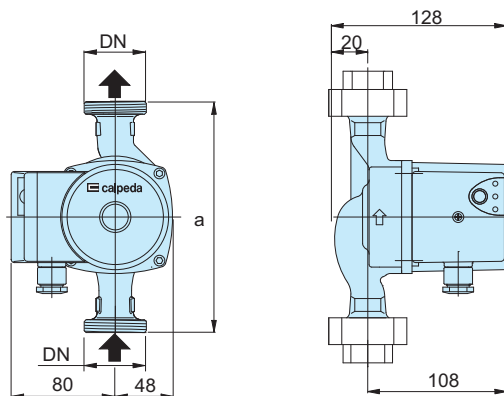

TYPE	DN	H m	Q m ³ /h	1~ 230 V		P1 W max	a mm	kg
				A min	A max			
NCE PS 20-40/130	G 1 1/4	4	3	0,05	0,2	20	130	2,2
NCE PS 25-40/130	G 1 1/2							2,2
NCE PS 20-60/130	G 1 1/4	6	3,5	0,05	0,32	35	130	2,2
NCE PS 25-60/130	G 1 1/2							2,2
NCE PS 20-80/130	G 1 1/4	8	4	0,05	0,5	55	130	2,2
NCE PS 25-80/130	G 1 1/2							2,2

Unions (on request)

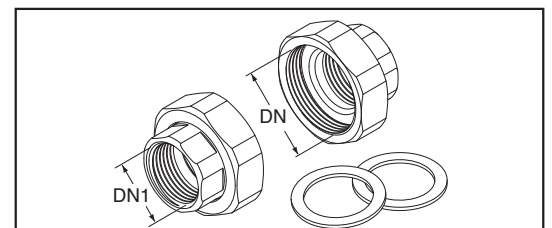

TYPE	DN	DN1
KIT G 1 - G 1/2 (NCE . 15..)	G 1	G 1/2
KIT G 1 1/4 - G 3/4 (NCE . 20..)	G 1 1/4	G 3/4
KIT G 1 1/2 - G 1 (NCE . 25..)	G 1 1/2	G 1
KIT G 2 - G 1 1/4 (NCE . 32..)	G 2	G 1 1/4